

# USER'S INFORMATION, MAINTENANCE AND SERVICE MANUAL

## HIGH EFFICIENCY TUBULAR HEAT EXCHANGER SERIES

### MODELS: PM9\*UP, FC9M\*UP, FL9M\*UP (Modulating Upflow)



#### TABLE OF CONTENTS

CONTACT INFORMATION .....	1	FURNACE MAINTENANCE SECTION .....	5
<b>USER'S INFORMATION</b> .....	<b>1</b>	FURNACE CLEANING SECTION .....	5
SAFETY .....	1	Burner Removal/Cleaning .....	5
INSTRUCTIONS FOR EXAMINING THE		Cleaning the Heat Exchanger .....	5
FURNACE INSTALLATION .....	2	Cleaning the Secondary Heat Exchanger .....	5
HOW YOUR GAS FURNACE WORKS .....	3	NORMAL OPERATION SEQUENCE .....	6
START-UP AND SHUTDOWN INSTRUCTIONS .....	3	ADJUSTMENT OF FAN CONTROL SETTINGS .....	6
Read the Instructions Below Before Trying to Start the Furnace ..	3	Hot Surface Ignition System .....	6
Operating Instructions: .....	3	TROUBLESHOOTING .....	6
To Turn Off the Appliance: .....	3	FURNACE CONTROL DIAGNOSTICS .....	7
FURNACE USER MAINTENANCE .....	3	DIAGNOSTIC FAULT CODE STORAGE AND RETRIEVAL .....	7
Air Filters .....	4	<b>REPLACEMENT PARTS LIST</b> .....	<b>8</b>
Replacing Filters .....	4	FIELD INSTALLED ACCESSORIES - NON-ELECTRICAL .....	10
Blower Care .....	4	REPLACEMENT PART CONTACT INFORMATION .....	10
Motor Lubrication .....	4	<b>WIRING DIAGRAM</b> .....	<b>11</b>
<b>SERVICE AND MAINTENANCE MANUAL</b> .....	<b>5</b>	<b>LIMITED WARRANTY</b> .....	<b>12</b>
SAFETY SECTION .....	5		

#### CONTACT INFORMATION

- Go to website at [www.york.com](http://www.york.com) click on "contact", then click on "contact form" and follow the instructions.
- Contact us by mail:

York International  
Consumer Relations  
5005 York Drive  
Norman, OK 73069

The manufacturer recommends that the user read all sections of this manual and keep the manual for future reference.

### **▲ WARNING**

**FIRE OR EXPLOSION HAZARD** - Failure to follow safety warnings exactly could result in serious injury, death, or property damage.

— **Do not store or use gasoline or other flammable vapors and liquids in the vicinity of this or any other appliance.**

— **WHAT TO DO IF YOU SMELL GAS:**

- Do not try to light any appliance.
- Do not touch any electrical switch; do not use any phone (included cell phone) in your building.
- Leave the building immediately.
- Immediately call your gas supplier from a neighbor's phone. Follow the gas supplier's instructions.
- If you cannot reach your gas supplier, call the fire department.

— **Installation and service must be performed by a qualified installer, service agency or the gas supplier.**

## SECTION I: USER'S INFORMATION

### SAFETY

1. The furnace area must be kept clear and free of combustible materials, gasoline and other flammable vapors and liquids.
2. Insulating materials may be combustible. The furnace must be kept free and clear of insulating materials. The furnace area must be examined when installed in an attic or other insulated space or when insulation is added to be sure that the insulation material has been kept away from the furnace.
3. The furnace needs air for combustion in order to operate properly and safely. Do not block or obstruct air openings on the furnace, air openings to the area where the furnace is installed, or spaces around the furnace.
4. Follow the instructions exactly as shown on the OPERATING INSTRUCTION LABEL or the Start-up and Shutdown Instructions on Page 3 of this manual when lighting the furnace or turning the furnace off.
5. Should the gas supply fail to shut off or if overheating occurs, shut off the gas valve to the furnace before shutting off the electrical supply.
6. Do not use this furnace if any part has been under water. A flood-damaged furnace is extremely dangerous. Attempts to use the furnace can result in fire or explosion. A qualified service agency should be contacted to inspect the furnace and replace all gas controls, control system parts, electrical parts that have been wet or the furnace if deemed necessary.

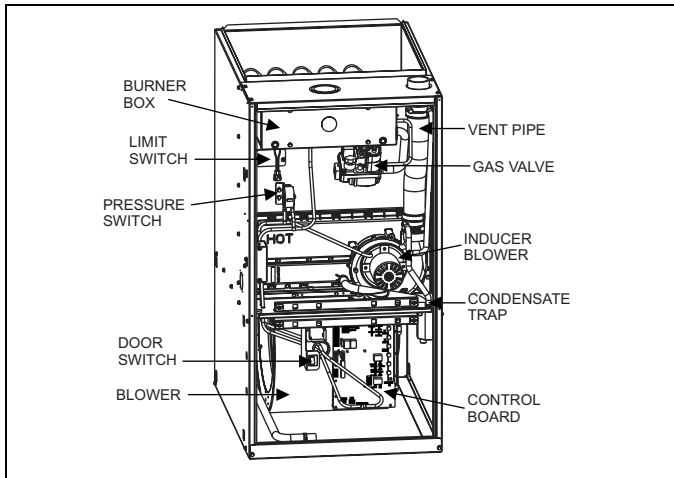

**FIGURE 1:** Component Locations

7. NEVER . . . Store flammable materials of any kind near your furnace. Gasoline, solvents, and other volatile liquids should be stored only in approved containers outside your home. These materials vaporize easily and are extremely dangerous.
8. NEVER . . . Store cleaning materials near your furnace. Materials such as bleaches, detergents, powdered cleansers, etc., can cause corrosion of the heat exchangers.
9. NEVER . . . Use the area around your furnace as a storage area for items which could block the normal flow of air. This flow of air is required for ventilation of the various furnace components.

**INSTRUCTIONS FOR EXAMINING THE FURNACE INSTALLATION**

It is the owner's responsibility to ensure that an annual inspection of the entire heating portion of the unit is made by a qualified service agency.

1. Examine the heat exchanger, vent/combustion air piping, vent connectors and chimney to be sure they are clear and free of obstructions.
2. Examine the vent pipe making sure it is firmly in place, that it slopes slightly upward and is physically sound without holes and all of the connections are secure.
3. Examine the return-air duct connections to make sure they are physically sound, sealed to the furnace casing, and the ducts terminate outside the space containing the furnace.
4. Examine the furnace casing making sure the physical support is sound without sagging, cracks or gaps. Examine the furnace base making sure it is physically sound without cracks, gaps or sagging and has a good seal.
5. Examine the furnace casing for obvious signs of deterioration.
6. Examine the burner flames to make sure they are in good adjustment. Refer to the pictorial sketch shown in Figure 2 as a comparison to the actual flame.
7. Examine the furnace as outlined above in steps "1 - 6" before each heating season. Use Figure 3 for visual reference.

**WARNING**

**FIRE OR EXPLOSION HAZARD**

*This furnace is designed and approved for use with Natural Gas and (LP) Propane Gas ONLY. DO NOT BURN ANY LIQUID FUEL OR SOLID FUEL IN THIS FURNACE. Burning any unapproved fuel will result in damage to the furnace heat exchanger, which could result in Fire, Personal Injury, and/or Property Damage.*

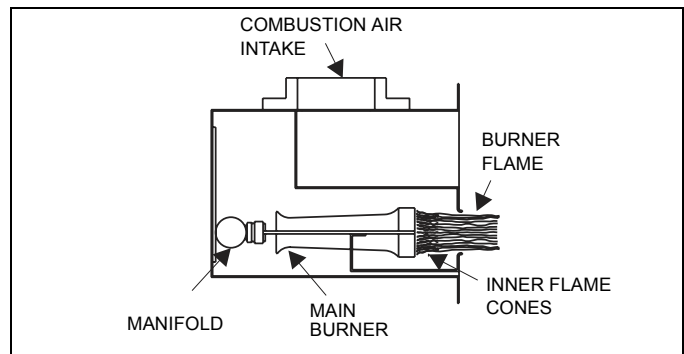

**FIGURE 2:** Burner Flame Drawing

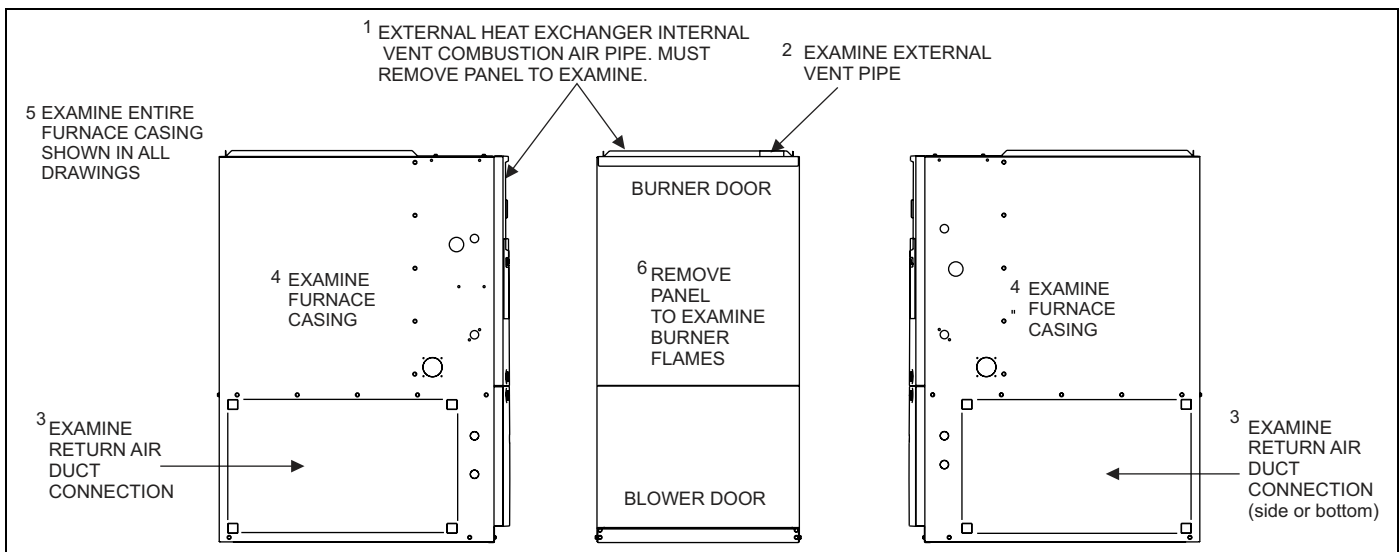

**FIGURE 3:** Furnace Examination Checkpoints

## HOW YOUR GAS FURNACE WORKS

Your furnace is a very easy appliance to take for granted. Season after season, it sits there in your home, keeping you warm and comfortable. For this reason, you may never have given much thought to the way your furnace operates. In order to get the safest and most efficient operation from your furnace, you should understand how your furnace does its job.

When you set your thermostat to provide more heat in your home, you are starting the heating cycle of the furnace. First, the inducer motor starts to purge the heat exchanger of any remaining gases. Next, the hot surface ignitor glows and after a warm-up period the gas valve opens and ignition occurs. A short time later, the blower starts and distributes the warm air throughout the home. The furnace control will vary the amount of heat and the amount of airflow needed to maintain the proper temperature in the home.

## START-UP AND SHUTDOWN INSTRUCTIONS

Read the Instructions Below Before Trying to Start the Furnace

### WARNING

*If you do not follow these instructions exactly, a fire or explosion may result causing property damage, personal injury, and/or loss of life.*

- This appliance does not have a pilot. It is equipped with an ignition device which automatically lights the burner. Do not try to light the burner by hand.
- BEFORE OPERATING; smell all around the appliance area for gas. Be sure to smell next to the floor because some gas is heavier than air and will settle on the floor.
- Use only your hand to push the gas control switch to the "on" position. Never use tools. If the switch will not operate by hand, don't try to repair it, call a qualified service technician. Force or attempted repair may result in a fire or explosion.
- Do not use this appliance if any part has been under water. Immediately call a qualified service technician to inspect the appliance and to replace any part of the control system and any gas control, which has been under water.

### Operating Instructions:

- STOP! Read the safety information above.
- Set the thermostat to the lowest setting.
- Turn off all electric power to the appliance.
- Remove burner door.
- Move gas control switch to the "OFF" position. Do not force. See Figure 4.
- Wait five (5) minutes to clear out any gas. If you then smell gas, STOP! Follow "B" in the safety information above. If you don't smell gas, go to next step.
- Move gas control switch to the "ON" position. Do not force. See Figure 4.
- Replace burner door.
- Turn on all electric power to the appliance.
- Set thermostat to the desired setting. Burner will light, which may take 30-60 seconds.
- After three (3) trials for ignition, if the appliance will not operate follow the instructions, "TO TURN OFF THE APPLIANCE" and call your service technician or gas supplier.

### To Turn Off the Appliance:

- Set the thermostat to lowest setting.
- Turn off all electric power to the appliance if service is to be performed.
- Remove upper access panel.
- Move gas control switch to the "OFF" position. See Figure 4.
- Replace burner access panel.

### WARNING

*Should overheating occur, or the gas valve fail to shut off, turn the external manual gas valve in the gas supply line to the furnace to the "off" position and let the furnace cool off before shutting off the electrical power supply. Refer to Figure 5.*

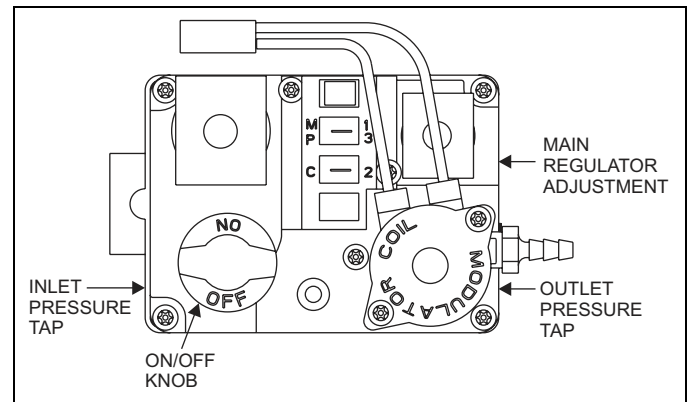

FIGURE 4: Gas Valve

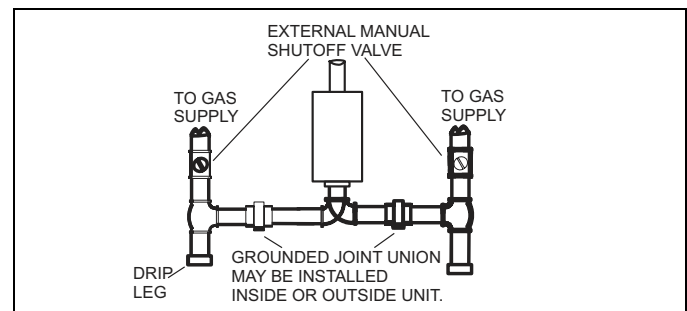

FIGURE 5: Gas Piping

**NOTE:** The spring-loaded safety cut-off switch, mounted under the blower deck will automatically cut off the electrical power supply to the furnace when the blower panel is removed. As a safety precaution, all electrical power and the gas supply to the furnace should be turned off before servicing.

## FURNACE USER MAINTENANCE

### WARNING

*Before proceeding, be sure the area is well ventilated. Turn the thermostat OFF. If the blower is running, wait until it stops automatically. Turn OFF the gas and electrical power supplies to the furnace. Check all metal parts and surfaces to be sure they have cooled to room temperature before you begin.*

Every time the filters are changed the following items should be visually inspected:

- Check combustion air and vent pipe for blockage or leakage.
- Check all components to be sure they are in good condition and that there are no obvious signs of deterioration.
- Check the drain lines to make sure there are no cracks or leaks.
- Check for dirt or lint on any surfaces or on components. Do not try to clean any of the surfaces or components. Cleaning of the furnace and its components must be done by a qualified service professional.

If, during the inspection of your furnace, you find any of the following conditions:

- Excessive amounts of dust and lint on components.
- Damaged or deteriorated components or surfaces.
- Leaks or blockage in the vent pipe passages.
- Water on any surface inside or outside of the furnace.

Do not operate the furnace, call a certified dealer / servicing contractor to check and / or clean your furnace, or for more information if you have questions about the operation of your furnace.

If all components appear to be in good operating condition, replace the front panels. Turn ON the gas and electrical power supplies to the furnace, and set thermostat to the desired temperature.

### Air Filters

Dirty filters greatly restrict the flow of air and may cause damage to the moving parts of the furnace. If the filters become clogged the heat exchangers and blower motor could overheat resulting in a potentially dangerous situation. The filters should be checked every 3 months. On new construction, check the filters every week for the first four weeks and every three weeks after that, especially if the indoor fan is running continuously. When replacing the filter(s) you must use filters that are the same size as those recommended in Table 1. Use the following procedure to determine the filter size. Never operate your furnace without a suitable air filter.

1. Measure the furnace width and use that measurement to determine the cabinet width.
  - A 17-1/2" wide cabinet is a "B" cabinet.
  - A 21" wide cabinet is a "C" cabinet.
  - A 24-1/2" wide cabinet is a "D" cabinet.
2. Locate the cabinet size on Table 1 then determine whether you have a bottom or side return air duct using the following method.
  - a. If the return air filter is on the left or right side of the furnace it is a side return
  - b. If the air filter is on the bottom of the furnace then you have a bottom return.
  - c. If the air filters are on the bottom and the side of the furnace then you have a bottom and side return. You must replace both air filters. Table 1 will indicate 2 filters by using brackets with the number two (2).
  - d. If the air filters are on both sides of the furnace then you have a two sided return. You must replace both air filters. Table 1 will indicate 2 filters by using brackets with the number two (2).
3. After you determine the cabinet size and what return configuration you have, look up the recommended filter size from Table 1.

### Replacing Filters

Filters used with this furnace must be installed external to the furnace casing. DO NOT attempt to install filters inside the furnace cabinet.

Some installations may have the air filter in a rack attached to the casing of the furnace or placed in the return air duct. If the filter location or replacement process is not obvious, contact your installer or service technician for assistance. Replace throw away filter(s) with the same size new filter(s). Throw away filter(s) may be replaced with cleanable filter(s) at this time. Cleanable filter(s) may be cleaned as described in the manufacturer instructions or as described below and then re-installed.

**TABLE 1: Filter Sizes**

Cabinet Size	Side (in)	Side (mm)	Bottom (in)	Bottom (mm)
17-1/2" (B)	16 x 25	406 x 635	16 x 25	406 x 635
21" (C)	16 x 25	406 x 635	20 x 25	508 x 635
24-1/2" (D)	(2) 16 x 25*	(2) 406 x 635*	22 x 25	559 x 635

\* Some installations of this model require only one filter.

### How to Clean your Filter

High-velocity filters may be cleaned with a vacuum cleaner or washed with a garden hose. Be sure to shake off excess water and allow filter to completely dry before re-installing the filter.

### Motor Lubrication

The motors in these furnaces are permanently lubricated, and do not require periodic oiling.

### Blower Care

Even with good filters properly in place, blower wheels and motors will become dust laden after long months of operation. The entire blower assembly should be inspected annually. If the motor and wheel are heavily coated with dust, they can be brushed and cleaned with a vacuum cleaner. If the blower cannot be properly cleaned without removing it from the furnace, then this service must be performed by a qualified service agency.

## ▲ WARNING

***Make sure you DO NOT move the clip on weight on the indoor fan wheel when cleaning the wheel. This weight is used to balance the wheel. Moving the weight will cause the fan wheel to vibrate.***

Every time the filters are changed the following items should be visually inspected:

- Check combustion air and vent pipe for blockage or leakage.
- Check all components to be sure they are in good condition and that there are no obvious signs of deterioration.
- Check the drain lines to make sure there are no cracks or leaks.
- Check for dirt or lint on any surfaces or on components. Do not try to clean any of the surfaces or components. Cleaning of the furnace and its components must be done by a qualified service professional.

If, during the inspection of your furnace, you find any of the following conditions:

- Excessive amounts of dust and lint on components.
- Damaged or deteriorated components or surfaces.
- Leaks or blockage in the vent pipe passages.
- Water on any surface inside or outside of the furnace.

Do not operate the furnace, call a certified dealer / servicing contractor to check and / or clean your furnace, or for more information if you have questions about the operation of your furnace.

If all components appear to be in good operating condition, replace the front panels. Turn ON the gas and electrical power supplies to the furnace, and set thermostat to the desired temperature.

## SECTION II: SERVICE AND MAINTENANCE MANUAL

### SAFETY SECTION

The following safety rules must be followed when servicing the furnace.

#### **⚠ WARNING**

##### **ELECTRIC SHOCK, FIRE OR EXPLOSION HAZARD**

*Failure to follow safety warnings exactly could result in dangerous operation, serious injury, death or property damage.*

*Improper servicing could result in dangerous operation, serious injury, and death or property damage.*

- Before servicing, disconnect all electrical power to the furnace.
- When servicing controls, label all wires prior to disconnecting. Reconnect wires correctly.
- Verify proper operation after servicing.

### FURNACE MAINTENANCE SECTION

The furnace should be cleaned and adjusted by a certified dealer or qualified service contractor once a year or before the start of every heating season. The following items must be cleaned and serviced or replaced if there are signs of deterioration.

1. The vent terminal.
2. The furnace vent and combustion air intake passageways. Should it be necessary to service the vent/air intake system, the manufacturer recommends this service be conducted by a qualified service agency. The operation of this appliance requires the reassembly and resealing of the vent/air intake system.
3. The furnace burners, ignitor and flame sensor.
4. The condensate collection and disposal system. If any disassembly of components containing flue or vent gases is required, a qualified service agency must perform the service.

### FURNACE CLEANING SECTION

**NOTE:** The cleaning operations listed below must be performed only by a qualified service agency.

#### Burner Removal/Cleaning

The main burners should be checked periodically for dirt accumulation. If cleaning is required, follow this procedure:

1. Turn off the electrical power to the unit.
2. Turn off the gas supply at the external manual shut-off valve and loosen the ground union joint.
3. Remove the burner door and remove the burner box cover.

4. Disconnect wires from flame sensor, rollout switch and HSI igniter. Remove igniter carefully, as it is easily broken.
5. Remove the screws that hold the burner box assembly to the vest panel and remove the assembly.
6. Remove burners from the burner assembly.
7. Burners may be cleaned by rinsing in hot water.
8. Reassemble the burners in the reverse order.

#### Cleaning the Heat Exchanger

1. Turn off the electrical power to the unit.
2. Turn off the gas supply at the external manual shut-off valve and loosen the ground union joint.
3. Remove the burner door and remove the burner box cover.
4. Disconnect wires from flame sensor, rollout switch and HSI igniter. Remove igniter carefully, as it is easily broken.
5. Remove the screws that hold the burner box assembly to the vest panel and remove the assembly.
6. Remove the vent pipe assembly, vent blower and condensate pan.
7. The heat exchanger is now exposed.
8. With a long flexible wire brush, clean inside each tube at both the top and bottom. The brush must pass around the rear heat exchanger tubes. Then vacuum loose the scale and dirt from each tube.
9. Replace all components in reverse order. Reconnect all wiring.
10. Restore electrical power and gas supply to the furnace.
11. Check furnace operation.

#### **⚠ CAUTION**

*Label all wires prior to disconnection when servicing controls. Wiring errors can cause improper and dangerous operation. Verify proper operation after servicing.*

#### Cleaning the Secondary Heat Exchanger

1. Follow steps 1 - 7 under cleaning the Heat Exchanger.
2. Remove the vent piping from the vent blower housing. Disconnect the drain lines from the vent blower housing and from the condensate drain pan. Remove the vent blower housing blower and the condensate pan.
3. Using a stiff wire brush, remove the loose scale or soot from each tube.
4. Vacuum the secondary heat exchanger.
5. Finish the cleaning procedure by following steps 9 - 11 under cleaning the Heat Exchanger.

### NORMAL OPERATION SEQUENCE

The furnace control calculates the optimum firing rate each time the wall thermostat R and W contacts close or open (at the beginning and at the end of each call for heat) based on information from the thermostat and past demand. UNLIKE CONVENTIONAL SYSTEMS, THE WALL THERMOSTAT DOES NOT SIMPLY TURN THE FURNACE ON AND OFF. THE FURNACE CONTROL CALCULATES THE DEMAND AND MAY CONTINUE TO FIRE THE FURNACE DURING PORTIONS OF THE THERMOSTAT "OFF" CYCLE.

When the wall thermostat R and W contacts close, indicating a call for heat, the following sequence occurs:

1. The inducer is energized and ramps up its speed until airflow is proven by the pressure switch and by the pressure sensor on the control board.
2. The hot surface ignitor is energized.
3. After a 17-20 second igniter heatup, the gas valve opens and the burners light.
4. When the control senses that flame is present, the circulating blower starts at low speed.
5. The furnace fires at 70% of full rate for 30-45 seconds, then drops to the minimum (35%) firing rate.
6. The firing rate is automatically adjusted to meet demand, increasing gradually to maximum (100%) firing rate if the thermostat is not satisfied within a defined time.
7. When the thermostat R and W contacts open (thermostat is satisfied) the furnace control recalculates the demand and a new firing rate.
  - a. If demand exceeds the minimum firing rate, the burners will continue to fire at a recalculated reduced firing rate, decreasing if the thermostat remains off for a defined time.
  - b. If demand does not exceed the minimum firing rate, the burners will shut off immediately.
8. After the burners shut off, the circulating blower will continue to run until the temperature sensor detects that the supply air temperature has dropped to the desired level, which should take from 30 to 90 seconds.

### ADJUSTMENT OF FAN CONTROL SETTINGS

**Cooling** - The airflow delivered by the furnace during cooling operation can be adjusted to match the cooling capacity of the A/C condensing unit. This is done by moving the COOL jumper on the control board to give the desired airflow.

**Do not move the motor wires to different positions on the furnace control board!**

The jumper has four positions, which will deliver sufficient airflow in cooling mode for the cooling capacities shown in the table below. The CFM delivery on each jumper position is shown in Table 14.

**TABLE 2:** Cooling Airflow - A/C Capacity in Tons

Models	Jumper Position			
	A	B	C	D
60/1200	1-1/2	2	2-1/2	3
80/1200	1-1/2	2	2-1/2	3
80/1600	2-1/2	3	3-1/2	4
100/1600	2-1/2	3	3-1/2	4
100/2000	3	3-1/2	4	5
120/2000	3	3-1/2	4	5

**Continuous Fan Operation** - The airflow delivered by the furnace during continuous fan operation can be adjusted as desired. This is done by moving the FAN jumper on the control board to give the desired airflow.

**Do not move the motor wires to different positions on the furnace control board!**

The jumper has three positions. The "A" position delivers maximum airflow, 100% of the blower capacity. Position "B" delivers approximately 70% of the blower capacity. And Position "C" delivers minimum airflow, approximately 40% of the blower capacity.

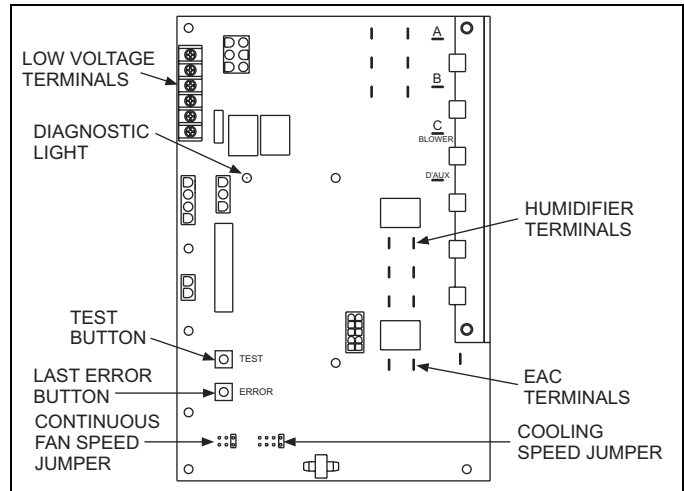

**FIGURE 6:** Furnace Control Board

### Hot Surface Ignition System

**WARNING**

**HOT SURFACE IGNITION SYSTEM**  
*Do not attempt to light this furnace by hand (with a match or any other means). There may be a potential shock hazard from the components of the hot surface ignition system. The furnace can only be lit automatically by its hot surface ignition system.*

### TROUBLESHOOTING

The following visual checks should be made before troubleshooting:

1. Check to see that the power to the furnace and the ignition control module is ON.
2. The manual shut-off valves in the gas line to the furnace must be open.
3. Make sure all wiring connections are secure.
4. Review the sequence of operation. Start the system by setting the thermostat above the room temperature. Observe the system's response. Then use the troubleshooting section in this manual to check the system's operation.

**WARNING**

*Never bypass any safety control to allow furnace operation. To do so will allow furnace to operate under potentially hazardous conditions.*  
*Do not try to repair controls. Replace defective controls with UPG Source 1 Parts.*  
*Never adjust pressure switch to allow furnace operation.*

## FURNACE CONTROL DIAGNOSTICS

This furnace has built-in self-diagnostic capability. If a system problem occurs, a flashing LED shows a fault code. The LED can flash red, green or amber to indicate various conditions. The LED is located on the furnace control board and can be seen through the clear view port in the lower door of the furnace. To indicate an error condition, the LED will turn on for 1/4 second and off for 1/4 second. The pattern will be repeated the number of times equal to the flash code. For instance, a "six flash code" will be indicated by the LED turning on and off six times. There will be a two second off period between each set of flashes. The flash codes and an indication of their likely causes are listed below:

**STEADY OFF** - No 24V power to board. Check the 24 volt control circuit fuse on the board. Check the circuit breaker or fuse on the 115 volt supply power to the furnace. Check that the 24 volt transformer.

**One Green Flash** - Normal Operation with no call for heat.

**Two Green Flashes** - Indicator for "No error codes in memory". See Diagnostic Fault Code Storage and Retrieval section below.

**Three Green Flashes** - Indicator for "Error codes cleared from memory". See Diagnostic Fault Code Storage and Retrieval section below.

**Rapid Green Flash** - Control is in "Factory Speedup" mode. This mode is used only during factory run-testing of the furnace. To stop this mode, cycle power to the furnace off and then back on.

**One Amber Flash** - Normal operation with call for cooling.

**Two Amber Flashes** - Normal operation with call for heat.

**Three Amber flashes** - Normal operation, burner is on at end of heating cycle after wall thermostat has been satisfied.

**Four Amber Flashes** - Heating capacity is reduced due to restriction in the circulating air system. Check for dirty filter or closed registers.

**Five Amber Flashes** - Heating capacity is reduced due to restriction in the combustion air or vent system. Check for blocked vent/air pipe or clogged condensate drain. Above 4,000 feet altitude, this may also indicate automatic, normal derating for altitude.

**Rapid Amber Flash** - Low flame sense current. Check for dirty or mis-located flame sensor rod.

**One Red Flash** - Flame is present with no power being supplied to gas valve. This can be caused by a gas valve that is slow to close or that leaks gas through to the burners.

**Two Red Flashes** - Stuck closed pressure switch. The control confirms that the pressure switch contacts are open at the beginning of each cycle. This could be caused by a faulty pressure switch or by mis-wiring of the pressure switch.

**Three Red Flashes** - Stuck open pressure switch. This indicates that the pressure switch is open when it should be closed. This could be caused by a faulty combustion air blower, blocked vent pipe, blocked air intake pipe, blocked condensate drain, faulty pressure switch hose or a faulty pressure switch.

**Four Red Flashes** - High limit switch open or 24 volt fuse is open. This may be caused by a dirty air filter, improperly sized duct system, faulty blower motor, restricted circulating airflow or an open fuse on the control board.

**Five Red Flashes** - Rollout switch or auxiliary limit switch open. Check the rollout switch on the side of the burner box. It is a manual reset switch. To reset, push the small button in the center of the switch. If it cannot be reset or if the switch trips again, contact a qualified serviceman. Check the limit switch mounted in the combustion air blower housing.

**Six Red Flashes** - Current failure on modulating gas valve.

**Seven Red Flashes** - Lockout due to no ignition. The control will try three times for ignition. If flame cannot be established in three tries, the control will lockout for one hour and then will try again to light. Check gas supply, ignitor, gas valve, flame sensor.

**Eight Red Flashes** - Lockout due to too many flame recycles. This flash code occurs if flame is lost five times during a single heating cycle. This could be caused by a faulty gas valve, low gas pressure, or dirty flame sensor. The control will lock out for one hour and then will try again.

**Nine Red Flashes** - Reversed line polarity or improper grounding. Check polarity of the incoming power to the furnace. Check the grounding of the furnace, including the transformer ground and the L1 and neutral connections.

**Ten Red Flashes** - Gas valve circuit shorted. Check gas valve wiring. If correct, replace gas valve.

**Eleven Red Flashes** - Main blower failure - This flash code occurs when the main limit opens and fails to reclose within five minutes, indicating that the blower motor or blower wheel has failed.

**Twelve Red Flashes** - ID plug is not present or not connected properly, check for loose plug or loose wires in plug.

**Steady On Red** - Control fault has been detected or there is 24 volts present without 115 volts. Check that there is 24 volts and 115 volts being supplied to the board. If so, then the board should be replaced.

## DIAGNOSTIC FAULT CODE STORAGE AND RETRIEVAL

The control in this furnace is equipped with memory that will store up to five error codes to allow a service technician to diagnose problems more easily. This memory will be retained even is power to the furnace is lost. **Only a qualified service technician should use this feature.**

The control stores up to five separate error codes. If more than five error codes have occurred since the last reset, only the five most recent will be retained. The furnace control board has a button, labeled "**LAST ERROR**" that is used to retrieve error codes. This function will only work if there are no active thermostat signals. So any call for heating, cooling or continuous fan must be terminated before attempting to retrieve error codes.

To retrieve the error codes, push the **LAST ERROR** button. The **LED** on the control will then flash the error codes that are in memory, starting with the most recent. There will be a two-second pause between each flash code. After the error codes have all been displayed, the **LED** will resume the normal slow green flash after a five second pause. To repeat the series of error codes, push the button again.

If there are no error codes in memory, the **LED** will flash two green flashes. To clear the memory, push the **LAST ERROR** button and hold it for more than five seconds. The **LED** will flash three green flashes when the memory has been cleared, then will resume the normal slow green flash after a five-second pause.

**SECTION III: REPLACEMENT PARTS LIST**

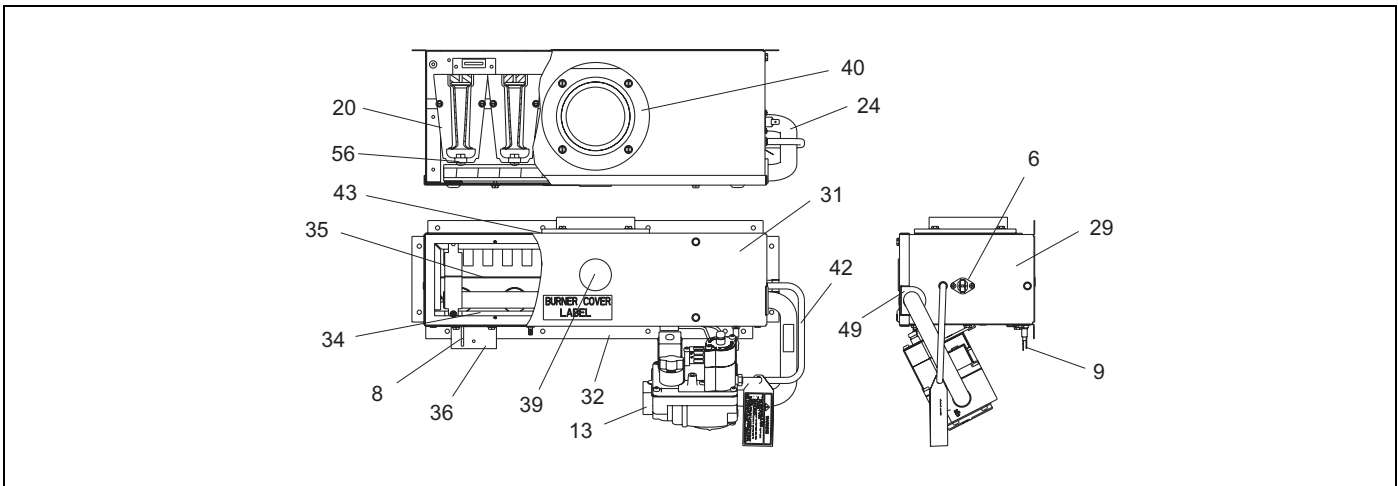
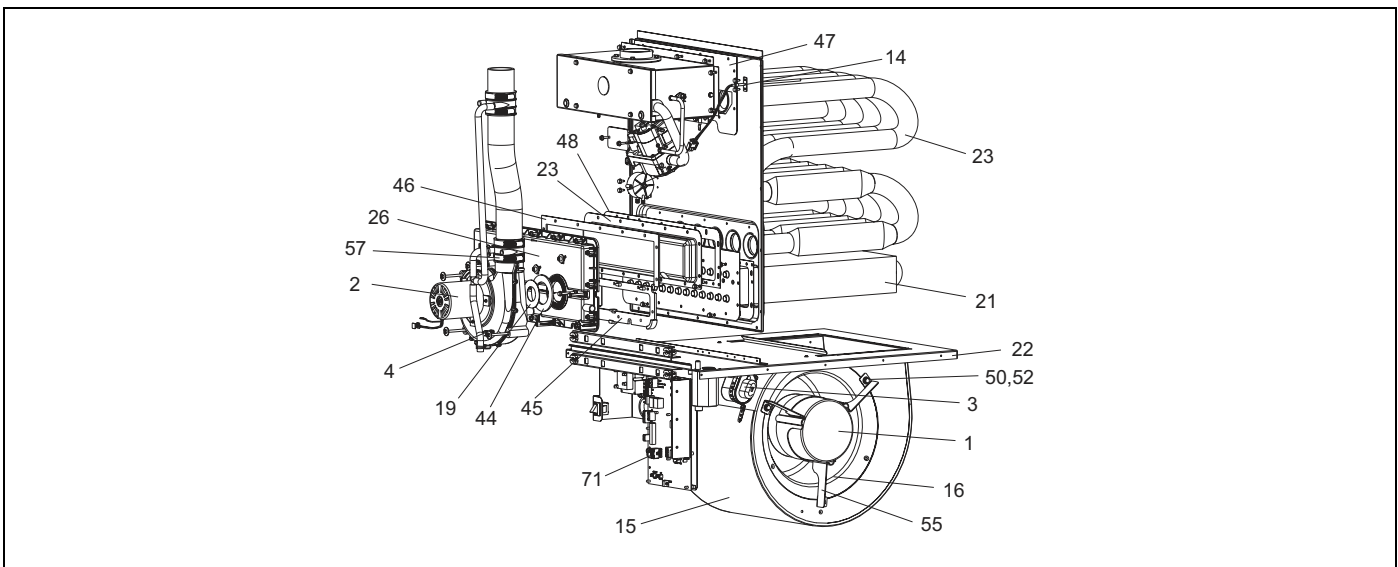
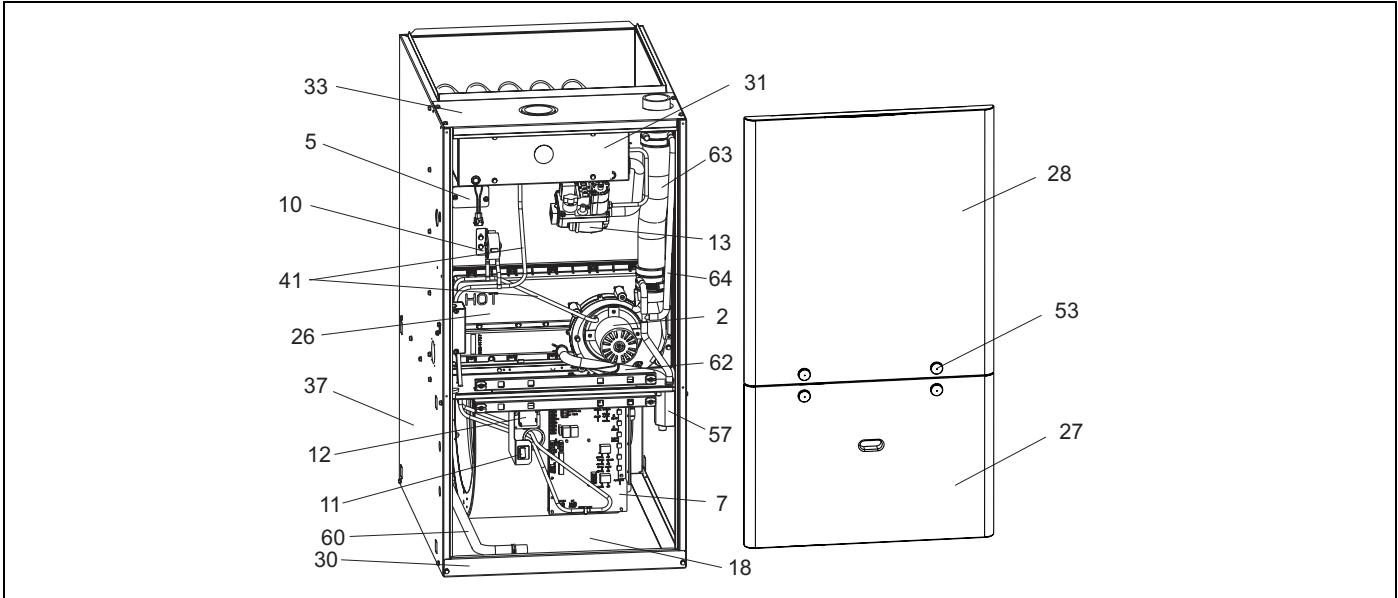

ITEM	DESCRIPTION
<b>MOTOR</b>	
1	MOTOR, MODULATING FURNACE
2	MOTOR, INDUCER ASS'Y
<b>ELECTRICAL</b>	
3	CAPACITOR, RUN (7.5MFD/370V)
4	SWITCH, LIMIT (INDUCER)
5	LIMIT, TEMPERATURE (Primary)
6	LIMIT, FLAME ROLL-OUT
7	CONTROL, FURNACE MODULATING
8	IGNITER
9	SENSOR, FLAME
10	SWITCH, PRESSURE
11	SWITCH, DOOR
12	TRANSFORMER
13	VALVE, GAS
14	SENSOR, THERMISTOR
<b>AIR MOVING</b>	
15	HOUSING, BLOWER
16	WHEEL, BLOWER
17	BRACKET, BLOWER MOUNTING (2 Req'd)
<b>FABRICATED PARTS</b>	
18	PANEL, BLOCK-OFF
19	COMBUSTION BLWR RESTRICTOR
20	BURNER, MAIN GAS
21	COIL, CONDENSING
22	SHELF, BLOWER
23	HEAT EXCHANGER ASS'Y
24	MANIFOLD, GAS
25	SHIELD, PAN
26	CONDENSATE PAN ASSEMBLY
27	PANEL, BLOWER ACCESS
28	ACCESS PANEL, UPPER
29	WRAPPER, BURNER BOX
30	CHANNEL, TOE PLATE
31	COVER, GAS CONTROL
32	BOTTOM PANEL, BURNER BOX
33	PANEL, TOP
34	SUPPORT, BURNER
35	PLATE, DIFFUSER
36	BRACKET, IGNITER
37	WRAPPER, INSULATED
38	

ITEM	DESCRIPTION
<b>MISCELLANEOUS</b>	
39	PLUG, WINDOW, CLEAR -1.5"
40	CONNECTOR AIR INTAKE 2"
41	HOSE ASSEMBLY, VACUM (2 Req'd)
42	TUBING, PREFORMED
43	GASKET, AIR INTAKE
44	GASKET, COMBUSTION BLOWER
45	GASKET, CONDENSATE PAN
46	GASKET, UPPER CONDENSATE PAN
47	GASKET, GAS CONTROLS
48	GASKET (COND. COIL/LOWER PAN) (2 Req'd)
49	GROMMET, MANIFOLD SEAL
50	GROMMET, MOTOR (3 Req'd)
51	GROMMET, 1/2" DIA.
52	FERRULE, MOTOR MOUNT(3 Req'd)
53	DOOR KNOB, BLACK (4 Req'd)
54	HARNESS, MAIN WIRING
55	MOUNT, 1 PC. MOTOR
56	ORIFICE, BURNER (Natural #45)
57	TRAP, CONDENSATE
58	WIRING DIAGRAM
59	DRAIN ASSY, INDUCER EXHAUST
60	DRAIN TUBE, CONDENSATE TRAP
61	DRAIN TUBE, COMBUSTION BLOWER
62	DRAIN TUBE, CONDENSATE PAN
63	VENT TUBE
64	DRAIN ASSY, DOUBLE GUTTER
65	LOCKNUT, CONDUIT (1/2")
66	ADAPTER, INSERT
67	BUSHING, THREADED
68	WASHER, FLAT FIBERGLASS (2 Req'd)
69	2" PVC
70	SIGHT GLASS, OVAL
71	JUMPER PLUG
72	SILCONE INSERT

NOTE: \*Not Shown

Major components and suggested stocking items are shown with shaded item number.



**FIELD INSTALLED ACCESSORIES - NON-ELECTRICAL**

MODEL NO.	DESCRIPTION	USED WITH
1NP0680	PROPANE (LP) CONVERSION KIT WITH GAS VALVE	ALL MODELS
1SF0101	EXTERNAL SIDE FILTER RACK	ALL MODELS
1CT0302	CONCENTRIC INTAKE/VENT 2"	60, 80, 100 INPUT MBH
1CT0303	CONCENTRIC INTAKE/VENT 3"	100, 120 MBH
1HT0901	SIDEWALL VENT TERMINATION	ALL MODELS
1BR0317	EXTERNAL BOTTOM FILTER RACK	17-1/2" CABINETS
1BR0321		21" CABINETS
1BR0324		24-1/2" CABINETS
1NK0301	CONDENSATE NEUTRALIZER KIT	ALL MODELS
1SF0101	SIDE RETURN FILTER KIT 1" FILTER	ALL MODELS
1SR0200	SIDE RETURN FILTER KIT 1-4" FILTER	ALL MODELS
1BR0117	BOTTOM RETURN FILTER KIT 1" FILTER	17-1/2" CABINETS
1BR0217	BOTTOM RETURN FILTER KIT 1-4" FILTER	17-1/2" CABINETS
1BR0121	BOTTOM RETURN FILTER KIT 1" FILTER	21" CABINETS
1BR0221	BOTTOM RETURN FILTER KIT 1-4" FILTER	21" CABINETS
1BR0124	BOTTOM RETURN FILTER KIT 1" FILTER	24-1/2" CABINETS
1BR0224	BOTTOM RETURN FILTER KIT 1-4" FILTER	24-1/2" CABINETS

**REPLACEMENT PART CONTACT INFORMATION**

This is a generic parts list. To request a complete parts list, refer to the contact information below:

- Visit our website at [www.source1parts.com](http://www.source1parts.com) for the following information:
  1. Search for a part or browse the catalog.
  2. Find a dealer or distributor.
  3. Customer Service contact information.
    - a. Click on the "Brand Links" button
    - b. Click on the "Customer Service" button
- You can contact us by mail. Just send a written request to:

**York International  
Consumer Relations  
5005 York Drive  
Norman, OK 73069**

# SECTION IV: WIRING DIAGRAM

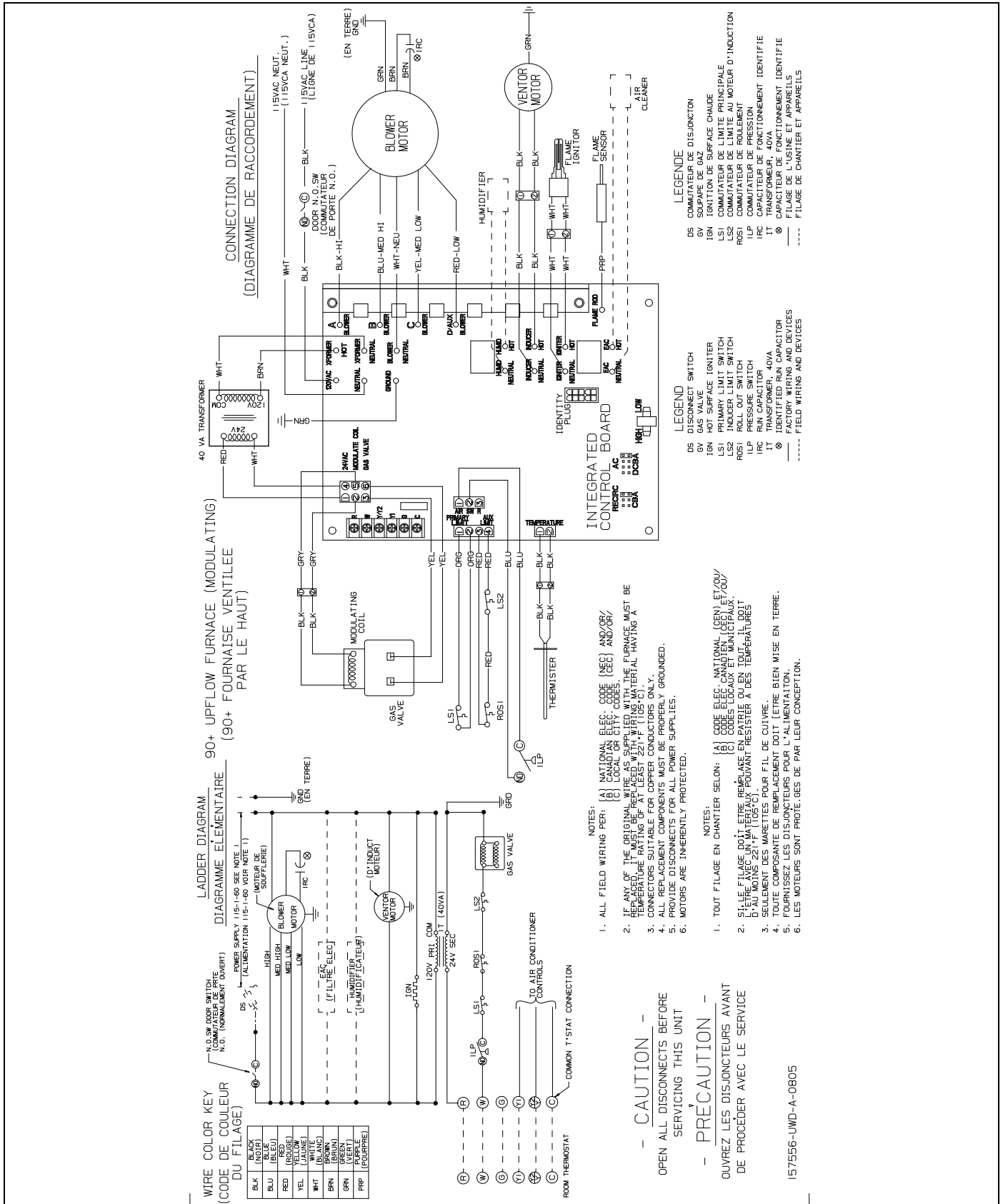

FIGURE 7: Wiring Diagram

# Limited Warranty

UPG warrants this product to be free from defects in factory workmanship and material under normal use and service and will, at its option, repair or replace any parts that prove to have such defects according to the terms outlined on this warranty. This warranty covers only the equipment described by the Product Model Number and Serial Number listed on the Warranty Registration Card.

UPG warrants the primary heat exchangers in the product to be free from defects in factory workmanship and material under normal use and service and will at its option, repair or furnish a replacement heat exchanger, either new or reconditioned, that meets the intended fit, use and function of the original heat exchanger for any heat exchanger furnished by UPG which proves to have such defects within the duration of warranty coverage. Alternatively, UPG may, at its option, extend a replacement allowance to be applied toward the purchase of a new furnace or packaged unit marketed by UPG. The exact amount of the allowance will be determined at the discretion of UPG, based upon current market conditions, but in no case shall this allowance exceed thirty (30) percent of the original consumer purchase price of the furnace, excluding such items as ductwork, wiring, piping and installation costs. UPG shall have no responsibility hereunder for installation, shipping, handling or other charges except as specifically provided herein.

For your benefit and protection, return the Warranty Registration Card to UPG promptly after installation. This will initiate the warranty period and allow us to contact you, should it become necessary. In the absence of a recorded Warranty Registration Card, the warranty period will begin upon product shipment from UPG.

This warranty extends only to the original consumer purchaser and is non-transferable. For this warranty to apply, the product must be installed according to UPG recommendations and specifications, and in accordance with all local, state, and national codes; and the product must not be removed from its place of original installation. The warranty period for repair or replacement parts provided hereunder shall not extend beyond the warranty period stated on the reverse side of this warranty

FURNACE TYPE		HEAT EXCHANGER			PARTS
		Residential Applications		Non-Residential Applications	
		Original Owner	Subsequent Owner		
90%	PM9*UP, FC9M*UP, FL9M*UP	Lifetime	20	10	5

UPG strongly recommends regular periodic preventative maintenance on this equipment. The person most familiar with the equipment in your HVAC system is a UPG dealer. The UPG dealer can ensure your maintenance program meets the conditions of the "UPG Warranty", maximize the efficiency of the equipment, and service your unit within the mandated guidelines with regard to unlawful discharge of refrigerants into the atmosphere.

This warranty applies only to products installed in the United States and Canada.

## EXCLUSIONS

This warranty does not cover any:

- Shipping, labor, or material charges.
- Damages resulting from transportation, installation, or servicing.
- Damages resulting from accident, abuse, fire, flood, alteration, or acts of God (tampering, altering, defacing or removing the product serial number will serve to void this warranty).
- Damages resulting from use of the product in a corrosive atmosphere.
- Damages resulting from inadequacy or interruption of electrical service or fuel supply, improper voltage conditions, blown fuses, or other like damages.
- Cleaning or replacement of filters.
- Damages resulting from failure to properly and regularly clean air and/or water side of condenser and evaporator.
- Damages resulting from: (I) freezing of condenser water or condensate; (II) inadequate or interrupted water supply; (III) use of corrosive water; (IV) fouling or restriction of the water circuit by foreign material or like causes.
- Damages resulting from operation with inadequate supply of air or water.
- Damages resulting from use of components or accessories not approved by UPG (vent dampers, etc.).
- Increase in fuel or electric cost.

THIS WARRANTY IS IN LIEU OF ALL OTHER WARRANTIES, EXPRESSED OR IMPLIED, INCLUDING THE IMPLIED WARRANTIES OF MERCHANTABILITY AND FITNESS FOR A PARTICULAR PURPOSE.

SOME STATES DO NOT ALLOW THE DISCLAIMER OF IMPLIED WARRANTY, SO THAT THE ABOVE DISCLAIMER MAY NOT APPLY TO YOU.

SOME STATES ALLOW ONLY A PARTIAL LIMITATION ON IMPLIED WARRANTIES TO LIMIT THE DURATION OF IMPLIED WARRANTIES TO THE DURATION OF THE EXPRESS WARRANTY. IN SUCH STATES, THE DURATION OF IMPLIED WARRANTIES IS HEREBY EXPRESSLY LIMITED TO THE DURATION OF THE EXPRESS WARRANTY ON THE FACE HEREOF.

IN NO EVENT, WHETHER AS A RESULT OF BREACH OF WARRANTY OR CONTRACT, TORT (INCLUDING NEGLIGENCE) STRICT LIABILITY OR OTHERWISE, SHALL UPG BE LIABLE FOR SPECIAL, INCIDENTAL, OR CONSEQUENTIAL DAMAGES, INCLUDING BUT NOT LIMITED TO LOSS OF USE OF THE EQUIPMENT OR ASSOCIATED EQUIPMENT, LOST REVENUES OR PROFITS, COST OF SUBSTITUTE EQUIPMENT OR COST OF FUEL OR ELECTRICITY. THE ABOVE LIMITATIONS SHALL INURE TO THE BENEFIT OF UPG'S SUPPLIERS AND SUBCONTRACTORS. THE ABOVE LIMITATION ON CONSEQUENTIAL DAMAGES SHALL NOT APPLY TO INJURIES TO PERSONS IN THE CASE OF CONSUMER GOODS.

SOME STATES DO NOT ALLOW THE EXCLUSION OR LIMITATION OF LIABILITY FOR CONSEQUENTIAL OR INCIDENTAL DAMAGES, OR FOR STRICT LIABILITY IN TORT, SO THAT THE ABOVE EXCLUSIONS AND LIMITATIONS MAY NOT APPLY TO YOU.

UPG DOES NOT ASSUME, OR AUTHORIZE ANY OTHER PERSON TO ASSUME FOR UPG, ANY OTHER LIABILITY FOR THE SALE OF THIS PRODUCT.

THIS WARRANTY GIVES YOU SPECIFIC LEGAL RIGHTS. YOU MAY ALSO HAVE OTHER RIGHTS WHICH VARY FROM STATE TO STATE.

For Owner's Information

PRODUCT MODEL NO. \_\_\_\_\_ INSTALLATION DATE \_\_\_\_\_  
 UNIT SERIAL NO. \_\_\_\_\_ INSTALLING DEALER \_\_\_\_\_

Subject to change without notice. Printed in U.S.A.  
 Copyright © by Unitary Products Group 2006. All rights reserved.

157554-UUM-D-0606  
 Supersedes: 157554-YUM-C-0406

**Unitary  
 Products  
 Group**

**5005  
 York  
 Drive**

**Norman  
 OK  
 73069**