

USER'S INFORMATION, MAINTENANCE AND SERVICE MANUAL

HIGH EFFICIENCY
TUBULAR HEAT EXCHANGER SERIES

MODELS: PV8 / FC8V / FL8V / LC8V / LL8V
Two Stage Variable Speed Upflow / Horizontal / LoNOx)



This product was manufactured in a plant whose quality system is certified/registered as being in conformity with ISO 9001.

TABLE OF CONTENTS

CONTACT INFORMATION	1	Burner Removal/Cleaning	5
USER'S INFORMATION	1	Cleaning the Heat Exchanger	5
SAFETY	1	Cleaning the Secondary Heat Exchanger	6
CONTACT INFORMATION	1	SEQUENCE OF OPERATION	6
INSTRUCTIONS FOR EXAMINING THE FURNACE		CFM / TIMER BOARD	6
INSTALLATION	2	HEATING AIRFLOW	7
HOW YOUR GAS FURNACE WORKS	3	Heating Indoor Fan Off Delay	7
START-UP AND SHUTDOWN INSTRUCTIONS	3	Continuous Blower:	7
Read the Instructions Below Before Trying to Start the Furnace	3	COOLING AIRFLOW	7
Operating Instructions:	3	CFM Board - Delay Tap Selection	7
To Turn Off the Appliance:	3	Hot Surface Ignition System	7
FURNACE USER MAINTENANCE	4	TROUBLESHOOTING	7
Air Filters	4	FURNACE DIAGNOSTICS	8
Removing Filters	4	DIAGNOSTIC FAULT CODE STORAGE AND RETRIEVAL	8
Blower Care	4	REPLACEMENT PARTS LIST	10
Motor Lubrication	4	FIELD INSTALLED ACCESSORIES - NON-ELECTRICAL	12
SERVICE AND MAINTENANCE MANUAL	5	REPLACEMENT PART CONTACT INFORMATION	12
SAFETY SECTION	5	WIRING DIAGRAM	13
FURNACE MAINTENANCE SECTION	5	LIMITED WARRANTY	16
FURNACE CLEANING SECTION	5		

CONTACT INFORMATION

- Go to website at www.york.com click on "contact", then click on "contact form" and follow the instructions.
- Contact us by mail:

York International
Consumer Relations
5005 York Drive
Norman, OK 73069

The manufacturer recommends that the user read all sections of this manual and keep the manual for future reference.

WARNING

FIRE OR EXPLOSION HAZARD - Failure to follow safety warnings exactly could result in serious injury, death, or property damage.

— **Do not store or use gasoline or other flammable vapors and liquids in the vicinity of this or any other appliance.**

— **WHAT TO DO IF YOU SMELL GAS:**

- Do not try to light any appliance.
- Do not touch any electrical switch; do not use any phone (including cell phone) in your building.
- Leave the building immediately.
- Immediately call your gas supplier from a neighbor's phone. Follow the gas supplier's instructions.
- If you cannot reach your gas supplier, call the fire department.

— **Installation and service must be performed by a qualified installer, service agency or the gas supplier.**

SECTION I: USER'S INFORMATION

SAFETY

1. The furnace area must be kept clear and free of combustible materials, gasoline and other flammable vapors and liquids.
2. Insulating materials may be combustible. The furnace must be kept free and clear of insulating materials. The furnace area must be examined when installed in an attic or other insulated space or when insulation is added to be sure that the insulation material has been kept away from the furnace.
3. The furnace needs air for combustion in order to operate properly and safely. Do not block or obstruct air openings on the furnace, air openings to the area where the furnace is installed, or spaces around the furnace.
4. Follow the instructions exactly as shown on the OPERATING INSTRUCTION LABEL or the Start-up and Shutdown Instructions on Page 3 of this manual when lighting the furnace or turning the furnace off.
5. Should the gas supply fail to shut off or if overheating occurs, shut off the gas valve to the furnace before shutting off the electrical supply.
6. Do not use this furnace if any part has been under water. A flood-damaged furnace is extremely dangerous. Attempts to use the furnace can result in fire or explosion. A qualified service agency should be contacted to inspect the furnace and replace all gas controls, control system parts, electrical parts that have been wet or the furnace if deemed necessary.

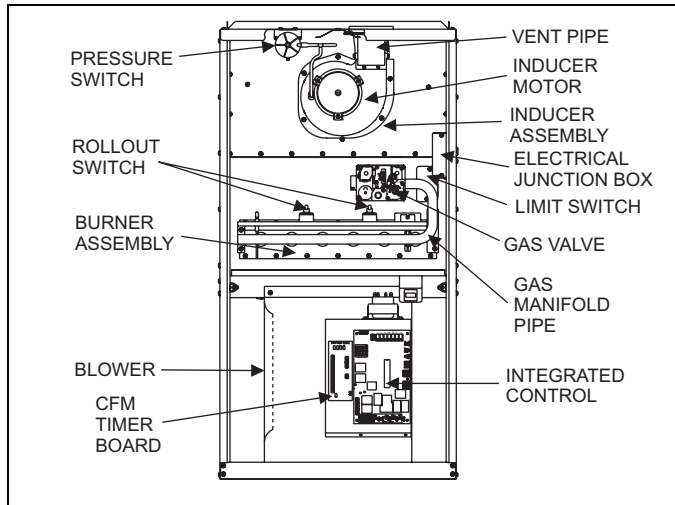

FIGURE 1: Component Locations

7. NEVER . . . Store flammable materials of any kind near your furnace. Gasoline, solvents, and other volatile liquids should be stored only in approved containers outside your home. These materials vaporize easily and are extremely dangerous.
8. NEVER . . . Store cleaning materials near your furnace. Materials such as bleaches, detergents, powdered cleansers, etc., can cause corrosion of the heat exchangers.
9. NEVER . . . Use the area around your furnace as a storage area for items which could block the normal flow of air. This flow of air is required for ventilation of the various furnace components.

WARNING

FIRE OR EXPLOSION HAZARD

This furnace is designed and approved for use with Natural Gas and (LP) Propane Gas ONLY. DO NOT BURN ANY LIQUID FUEL OR SOLID FUEL IN THIS FURNACE.

Burning any unapproved fuel will result in damage to the furnace heat exchanger, which could result in Fire, Personal Injury, and/or Property Damage.

INSTRUCTIONS FOR EXAMINING THE FURNACE INSTALLATION

It is the owner's responsibility to ensure that an annual inspection of the entire heating portion of the unit is made by a qualified service agency. Examine the furnace as outlined below in steps "1 - 6" before each heating season. Use Figure 3 for visual reference.

1. Examine the heat exchanger, vent pipe, combustion air passes gas, vent connectors and chimney to be sure they are clear and free of obstructions.
2. Examine the vent pipe making sure it is firmly in place, that it slopes slightly upward and is physically sound without holes and all of the connections are secure.
3. Examine the return-air duct connections to make sure they are physically sound, sealed to the furnace casing, and the ducts terminate outside the space containing the furnace.
4. Examine the furnace casing making sure the physical support is sound without sagging, cracks or gaps. Examine the furnace base making sure it is physically sound without cracks, gaps or sagging and has a good seal.
5. Examine the furnace casing for obvious signs of deterioration.
6. Examine the burner flames to make sure they are in good adjustment. Refer to the pictorial sketch shown in Figure 2 as a comparison to the actual flame.

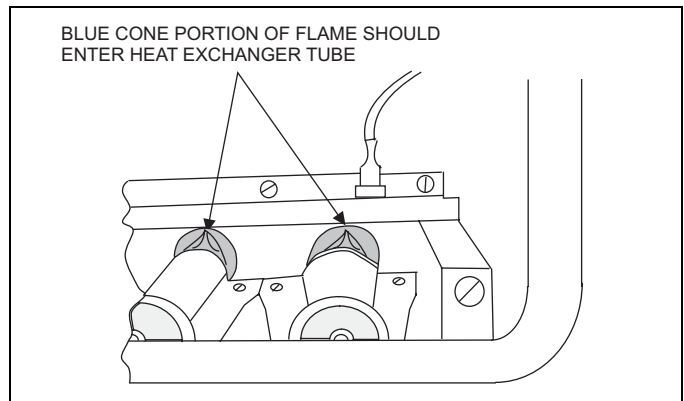

FIGURE 2: Burner Flame Drawing

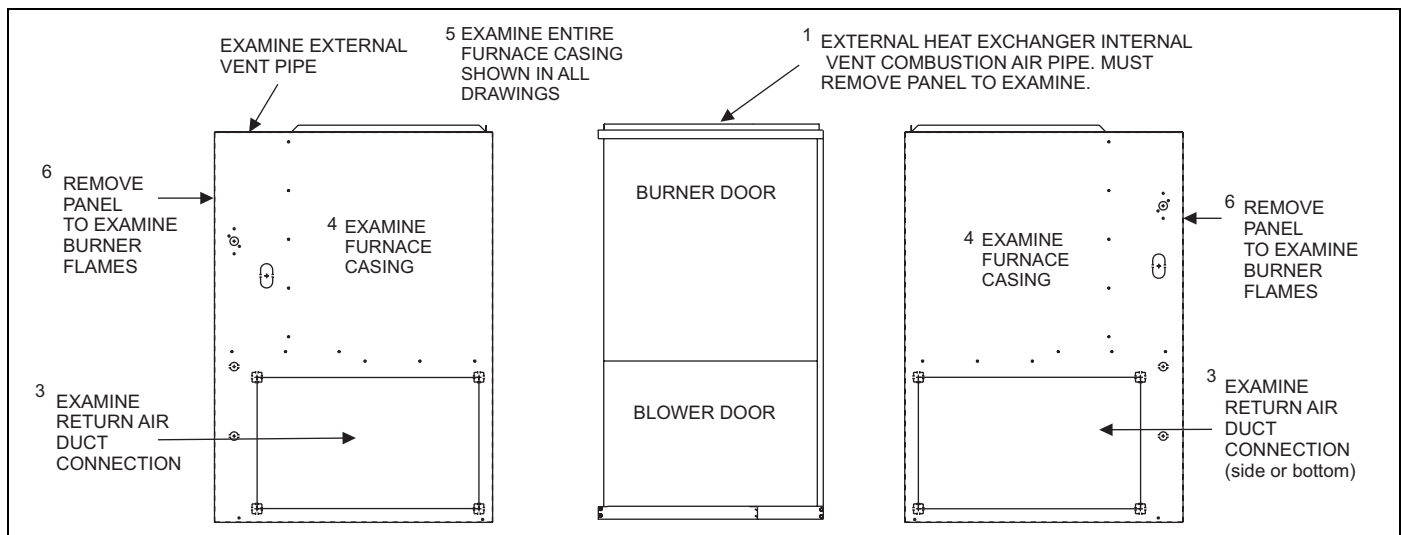

FIGURE 3: Furnace Examination Checkpoints

HOW YOUR GAS FURNACE WORKS

Your furnace is a very easy appliance to take for granted. Season after season, it sits there in your home, keeping you warm and comfortable. For this reason, you may never have given much thought to the way your furnace operates. In order to get the safest and most efficient operation from your furnace, you should understand how your furnace does its job.

When you set your thermostat to provide more heat in your home, you are starting the heating cycle of the furnace. First, the inducer motor starts to purge the heat exchanger of any remaining gases. Next, the hot surface ignitor glows and after a warm-up period the gas valve opens and ignition occurs. A short time later, the blower starts and distributes the warm air throughout the home. When the temperature setting on your thermostat is reached, the gas valve closes, the main burners are turned off, and the blower continues to run until the remaining warm air in the system is distributed. When the blower stops, the heating cycle has ended.

START-UP AND SHUTDOWN INSTRUCTIONS

Read the Instructions Below Before Trying to Start the Furnace

WARNING

If you do not follow these instructions exactly, a fire or explosion may result causing property damage, personal injury, and/or loss of life.

- This appliance does not have a pilot. It is equipped with an ignition device which automatically lights the burner. Do not try to light the burner by hand.
- BEFORE OPERATING**; smell all around the appliance area for gas. Be sure to smell next to the floor because some gas is heavier than air and will settle on the floor.
- Use only your hand to push the gas control switch to the "on" position. Never use tools. If the switch will not operate by hand, don't try to repair it, call a qualified service technician. Force or attempted repair may result in a fire or explosion.
- Do not use this appliance if any part has been under water. Immediately call a qualified service technician to inspect the appliance and to replace any part of the control system and any gas control, which has been under water.

Operating Instructions:

- STOP! Read the safety information above.
- Set the thermostat to the lowest setting.
- Turn off all electric power to the appliance.
- Remove burner door.
- Move gas control switch to the "OFF" position. Do not force. See Figure 4.
- Wait five (5) minutes to clear out any gas. If you then smell gas, STOP! Follow "B" in the safety information above. If you don't smell gas, go to next step.
- Move gas control switch to the "ON" position. Do not force. See Figure 4.
- Replace burner door.
- Turn on all electric power to the appliance.
- Set thermostat to the desired setting. Burner will light, which may take 30-60 seconds.

- After three (3) trials for ignition, if the appliance will not operate follow the instructions, "TO TURN OFF THE APPLIANCE" and call your service technician or gas supplier.

To Turn Off the Appliance:

- Set the thermostat to lowest setting.
- Turn off all electric power to the appliance if service is to be performed.
- Remove burner access panel.
- Move gas control switch to the "OFF" position. See Figure 4.
- Replace burner door.

WARNING

Should overheating occur, or the gas valve fail to shut off, turn the external manual gas valve in the gas supply line to the furnace to the "off" position and let the furnace cool off before shutting off the electrical power supply. Refer to Figure 5 or 6.

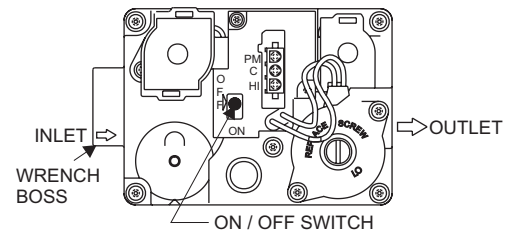

FIGURE 4: Gas Valve

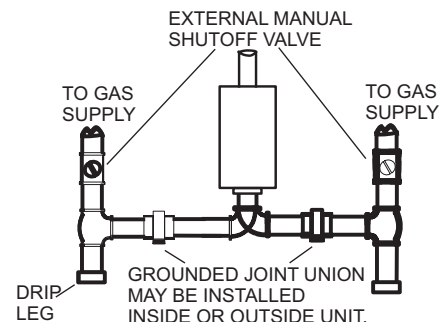

FIGURE 5: Upflow Gas Piping

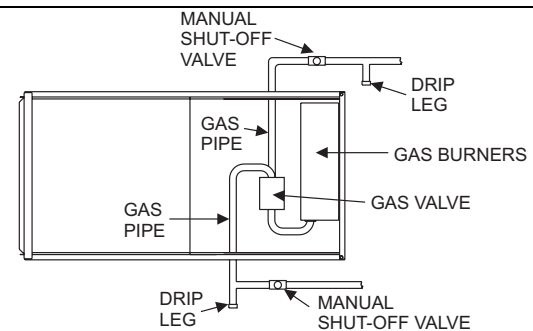

FIGURE 6: Horizontal Gas Piping

NOTE: The spring-loaded safety cut-off switch, mounted under the blower deck will automatically cut off the electrical power supply

FURNACE USER MAINTENANCE

WARNING

Before proceeding, be sure the area is well ventilated. Turn the thermostat OFF. If the blower is running, wait until it stops automatically. Turn OFF the gas and electrical power supplies to the furnace. Check all metal parts and surfaces to be sure they have cooled to room temperature before you begin.

Every time the filters are changed the following items should be visually inspected:

- Check vent pipe for blockage or leakage.
- Check all components to be sure they are in good condition and that there are no obvious signs of deterioration.
- Check for dirt or lint on any surfaces or on components. Do not try to clean any of the surfaces or components. Cleaning of the furnace and its components must be done by a qualified service professional.

If, during the inspection of your furnace, you find any of the following conditions:

- Excessive amounts of dust and lint on components.
- Damaged or deteriorated components or surfaces.
- Leaks or blockage in the vent pipe passages.
- Water on any surface inside or outside of the furnace.

Do not operate the furnace, call a certified dealer / servicing contractor to check and / or clean your furnace, or for more information if you have questions about the operation of your furnace.

If all components appear to be in good operating condition, replace the front panels. Turn ON the gas and electrical power supplies to the furnace, and set thermostat to the desired temperature.

Air Filters

Dirty filters greatly restrict the flow of air and may cause damage to the moving parts of the furnace. If the filters become clogged the heat exchangers and blower motor could overheat resulting in a potentially dangerous situation. The filters should be checked every 3 months. On new construction, check the filters every week for the first four weeks and every three weeks after that, especially if the indoor fan is running continuously. When replacing the filter(s) you must use filters that are the same size as those recommended in Table 1. Use the following procedure to determine the filter size. Never operate your furnace without a suitable air filter.

1. Measure the furnace width and use that measurement to determine the cabinet width.
 - A 14-1/2" wide cabinet is a "A" cabinet.
 - A 17-1/2" wide cabinet is a "B" cabinet.
 - A 21" wide cabinet is a "C" cabinet.
 - A 24-1/2" wide cabinet is a "D" cabinet.
2. Locate the cabinet size on Table 1 then determine whether you have a bottom or side return air duct using the following method.
 - a. If the return air filter is on the left or right side of the furnace it is a side return
 - b. If the air filter is on the bottom of the furnace then you have a bottom return.
 - c. If the air filters are on the bottom and the side of the furnace then you have a bottom and side return. You must replace both air filters. Table 1 will indicate 2 filters by using brackets with the number two (2).
 - d. If the air filters are on both sides of the furnace then you have a two sided return. You must replace both air filters. Table 1 will indicate 2 filters by using brackets with the number two (2).

3. After you determine the cabinet size and what return configuration you have, look up the recommended filter size from Table 1.

Removing Filters

Externally Mounted Air Filters

Some installations may have the air filter in a rack attached to the casing of the furnace or placed in the return air duct. You can gain access to the filter by pulling on the door or unscrewing the retaining screw, then slide the filter(s) out of its channel. Replace throw away filter(s) with the same size new filter(s). Throw away filter(s) may be replaced with cleanable filter(s) at this time. Cleanable filter(s) may be cleaned as described in the manufacturer instructions or as described below and then re-installed.

To replace the filter after cleaning you must do the following:

1. Slide filter into place.
2. Snap the door on or place the door in position and tighten the retaining screws, if provided.
3. Make sure the door is secure to the end of the filter rack.

TABLE 1: Filter Sizes

Cabinet Size	Side (in)	Side (cm)	Bottom (in)	Bottom (cm)
A	16 x 26	40.6 x 66.0	14 x 26	35.6 x 66.0
B	16 x 26	40.6 x 66.0	16 x 26	40.7 x 66.0
C	(2) 16 x 26	(2) 40.6 x 66.0	20 x 26	50.8 x 66.0
C	(2) 16 x 26	(2) 40.6 x 66.0	20 x 26	50.8 x 66.0

How to Clean your Filter

High-velocity filters may be cleaned with a vacuum cleaner or washed with a garden hose. Be sure to shake off excess water and allow filter to completely dry before re-installing the filter.

Blower Care

Even with good filters properly in place, blower wheels and motors will become dust laden after long months of operation. The entire blower assembly should be inspected annually. If the motor and wheel are heavily coated with dust, they can be brushed and cleaned with a vacuum cleaner. If the blower cannot be properly cleaned without removing it from the furnace, then this service must be performed by a qualified service agency.

WARNING

Make sure you DO NOT move the clip on weight on the indoor fan wheel when cleaning the wheel. This weight is used to balance the wheel. Moving the weight will cause the fan wheel to vibrate.

Motor Lubrication

The motors in these furnaces are permanently lubricated, and do not require periodic oiling.

Every time the filters are changed the following items should be visually inspected:

- Check combustion air and vent pipe for blockage or leakage.
- Check all components to be sure they are in good condition and that there are no obvious signs of deterioration.
- Check the drain lines to make sure there are no cracks or leaks.
- Check for dirt or lint on any surfaces or on components. Do not try to clean any of the surfaces or components. Cleaning of the furnace and its components must be done by a qualified service professional.

If, during the inspection of your furnace, you find any of the following conditions:

- Excessive amounts of dust and lint on components.
- Damaged or deteriorated components or surfaces.
- Leaks or blockage in the vent pipe passages.
- Water on any surface inside or outside of the furnace.

Do not operate the furnace, call a certified dealer / servicing contractor to check and / or clean your furnace, or for more information if you have questions about the operation of your furnace.

If all components appear to be in good operating condition, replace the front panels. Turn ON the gas and electrical power supplies to the furnace, and set thermostat to the desired temperature.

SECTION II: SERVICE AND MAINTENANCE MANUAL

SAFETY SECTION

The following safety rules must be followed when servicing the furnace.

⚠ WARNING

ELECTRIC SHOCK, FIRE OR EXPLOSION HAZARD

Failure to follow safety warnings exactly could result in dangerous operation, serious injury, death or property damage.

Improper servicing could result in dangerous operation, serious injury, and death or property damage.

- Before servicing, disconnect all electrical power to the furnace.
- When servicing controls, label all wires prior to disconnecting. Reconnect wires correctly.
- Verify proper operation after servicing.

FURNACE MAINTENANCE SECTION

The furnace should be cleaned and adjusted by a certified dealer or qualified service contractor once a year or before the start of every heating season. The following items must be cleaned and serviced or replaced if there are signs of deterioration.

1. The vent terminal screen (if applicable).
2. The furnace vent passageways. Should it be necessary to service the vent/air intake system, the manufacturer recommends this service be conducted by a qualified service agency. The operation of this appliance requires the reassembly and resealing of the vent/air intake system.
3. The furnace burners, ignitor and flame sensor.

FURNACE CLEANING SECTION

NOTE: The cleaning operations listed below must be performed only by a qualified service agency.

Burner Removal/Cleaning

The main burners should be checked periodically for dirt accumulation. If cleaning is required, follow this procedure:

1. Turn off the electrical power to the unit.
2. Turn off the gas supply at the external manual shut-off valve and loosen the ground union joint.
3. Remove the upper burner door and remove the burner box cover.
4. Disconnect wires from flame sensor, rollout switch and HSI igniter. Remove igniter carefully, as it is easily broken.

5. Remove the screws that hold the burner box assembly to the vest panel and remove the assembly.
6. Remove burners from the burner assembly.
7. Burners may be cleaned by rinsing in hot water.
8. Reassemble the burners in the reverse order.

Cleaning the Heat Exchanger

Lower Heat Exchanger Access

1. Turn off the electrical power to the unit and turn off gas supply at the shutoff valve.
2. Remove the blower and burner compartment access doors. Disconnect the gas supply piping at the union to permit removal of the entire burner and gas control assembly from the vestibule panel. Use the wrench boss on the gas valve when removing or installing this piping. See Figure 4.
3. Unplug the igniter from the wire harness. Disconnect sensor and rollout switch wires located on top of the air shield. Identify and note the location of all leads for ease of reinstallation. Also disconnect the wires at the side rollout switches (upflow only) and the gas valve wires.
4. Remove the screws holding the burner assembly to the vestibule panel and remove this assembly. Handle the assembly carefully since it contains the igniter, which is fragile and easily broken. The lower portion of the heat exchanger will now be exposed. To clean the burner assembly, use a vacuum cleaner, or remove the burners as outlined in burner cleaning, and clean in hot water.

Upper Heat Exchanger Access

1. Perform steps 1-4 above.
2. Disconnect vent piping from the vent motor assembly at the top panel on the furnace (upflow only). On downflow models, the vent pipe is secured to the vent motor outlet with a screw. Remove this screw before proceeding.
3. Unplug the vent motor wires and ground wire. Remove the pressure switch tubing at the top on the vent motor housing.

NOTE: It is recommended that replacement gaskets be available before removing vent motor.

1. Remove six mounting screws that hold the vent motor to the restrictor plate. The surface is gasketed and the gasket can be reused if it is carefully removed. It is necessary to remove this assembly to gain access to the restrictor plate mounting holes. The assembly may be vacuumed if cleaning is necessary. If any vent assembly parts are damaged, replace with an entire new assembly (except for gaskets).
2. Remove the perimeter screws attaching the restrictor plate assembly to the vestibule panel. The surface is also gasketed. The assembly, including the flue baffle plate (rear) may be vacuumed or cleaned with hot water if necessary.
3. The upper portion of the heat exchanger is now accessible. With a long flexible wire brush, clean inside each tube at both the top and bottom. The brush must pass around the rear heat exchanger tubes. Vacuum loose scale and dirt from each tube.
4. Clean - Replace all components in reverse order. Re-gasket all surfaces which required a gasket. Reconnect all wiring. Reattach vent pipe and gas supply lines before restoring service to furnace. Restore electrical power, check gas supply piping for leaks, and then verify furnace operation.

⚠ CAUTION

Label all wires prior to disconnection when servicing controls. Wiring errors can cause improper and dangerous operation. Verify proper operation after servicing.

Cleaning the Secondary Heat Exchanger

1. Follow steps 1 - 8 under cleaning the Heat Exchanger.
2. Remove the vent piping from the vent blower housing. Disconnect the drain lines from the vent blower housing and from the condensate drain pan. Remove the vent blower housing blower and the condensate pan. The turbulators can then be gently removed from the secondary heat exchanger.
3. Using a stiff wire brush, remove the loose scale or soot from each tube.
4. Vacuum the secondary heat exchanger.
5. Finish the cleaning procedure by following steps 11 thru 13 under cleaning the Heat Exchanger.

SEQUENCE OF OPERATION

The following describes the sequence of operation of the furnace. Refer to Figure 1 for component location.

1. Call for 1st stage only
 - On a call for 1st stage heat, the thermostat closes a circuit between R and W1.
 - The Microprocessor in the Furnace Control runs a 'Self Check'.
 - The Control checks the Primary Limit, Auxiliary Limit, and Roll-out Switches for closed contacts.
 - The Control checks that the Low Fire Pressure Switch (1LP) is open.
 - The Inducer Motor is energized on high speed, closing the contacts of 1LP.
 - The Control checks that 1LP is closed.
 - The Igniter is energized for 17 seconds.
 - The Gas Valve is energized on 1st Stage (Low Fire).
 - Flame Rectification is recognized within 7 seconds.
 - The Inducer is switched to low speed.
 - 30 seconds after flame is proven, the 'Heat Low' relay is energized providing 120 Volts AC to the Blower Motor.
 - At the same time, the EAC and Hum relays are energized, providing 120 Volts AC to the EAC Hot and Hum terminals.
2. Call for 2nd Stage after 1st Stage is operating
 - A call for 2nd Stage can be made by a 2-Stage thermostat, or by the W2 delay timer on the furnace control.
 - The Inducer Motor is shifted to high speed by the control, closing the contacts of 2LP (The High Fire Pressure Switch.).
 - The Control checks that 2LP is closed.
 - The Gas Valve is energized on 2nd Stage (High Fire).
 - The Control simultaneously de-energizes the Heat Low relay and energizes the Heat High relay, providing 120 Volts AC to a different speed of the Blower Motor.
3. 2nd Stage is satisfied, 1st Stage still calling.
 - If a Single Stage Thermostat is used, the Furnace will stay on High Fire until the thermostat is satisfied.
 - When the circuit between R and W2 is opened, the Control switches the Inducer Motor to low speed, causing the contacts of 2LP to open.
 - When 2LP opens, 2nd Stage of the Gas Valve is de-energized.
 - 30 seconds later, the Control switches the Blower from Heat High to Heat Low.
4. 1st Stage Satisfied
 - The Thermostat opens the circuit between R and W1
 - Immediately the Gas Valve is de-energized and Flame Rectification is lost.
5. 1st and 2nd Stage called simultaneously
 - The Inducer Motor is de-energized after a 15 second Post Purge and the Hum terminal is de-energized.
 - The 'Fan Off Delay' circuit is initiated. The Delay time can be field set at 60, 90, 120, or 180 seconds. It comes from the factory set at 60 seconds.
 - The Heat Low terminal is de-energized; stopping the Blower and the EAC terminal is de-energized.
5. 1st and 2nd Stage called simultaneously
 - The 1st stage call is processed as described in paragraph 1 above.
 - Once Flame Rectification is established, 2nd Stage is entered immediately as described in paragraph 2 above.
6. 1st and 2nd Stage satisfied simultaneously
 - Both stages of the Gas Valve are de-energized.
 - Flame Rectification is lost.
 - The Inducer and Hum relays are de-energized after a 15-second post purge.
 - 30 seconds later the Control shifts the Blower from Heat High to Heat Low.
 - After the Blower-Off Delay Circuit is satisfied, the Blower and EAC are de-energized.
7. Manual Fan Operation
 - With the thermostat in the Fan On position, a circuit is completed between R and G of the Control.
 - The Heat Low and EAC relays are energized by the Control.
8. Call for Cooling
 - The thermostat closes two circuits R to Y/Y2 and R to G. Since the Outdoor Unit is connected to Y and C at the Control, it is energized.
 - The Cool and EAC relays are energized by the Control.
 - A Blower-Off Delay Timing Circuit is energized by the call on Y.
9. Cooling call satisfied
 - The thermostat opens the R to Y/Y2 and R to G circuits.
 - The Outdoor Unit is de-energized.
 - The 60-second, Blower-Off Delay, timing circuit is initiated.
 - After 60 seconds, the Cool and EAC relays are de-energized.
10. Two-stage cooling. This furnace is equipped to handle a two-stage AC unit.
 - The wall thermostat will energize the Y1 circuit for low cooling and the Y2 circuit for high cooling.

CFM / TIMER BOARD

Variable speed motors will adjust the motor speed in order to maintain the indoor fan CFM. The CFM / Timer Board is used to control the blower speed thus the CFM when the unit is operating in the heating or cooling modes. The blower CFM for cooling can be modified by changing the jumper pin position on the taps selection marked COOL and ADJ.

The blower CFM for heating can be modified by changing the jumper pin position on the taps selection marked HEAT and ADJ. The taps selection pins have been preset at the factory to provide the maximum CFM. Table 16 in the installation manual list the recommended jumper pin settings.

If a lesser CFM is required for a specific HVAC system the taps selection pins can be moved to the "B", "C", or "D" positions. Pin "A" will provide the highest CFM and "D" will provide the lowest CFM. The taps selection marked DELAY are used for cooling only. The recommended settings for these jumper pins are listed in Delay taps selection.

HEATING AIRFLOW

The heating airflow has been preset at the factory to provide maximum CFM. If a lesser CFM is required for a specific HVAC system the "JUMPER" on the HEAT selection pins on the CFM-Timer Board may be moved to tap "B", "C", or "D".

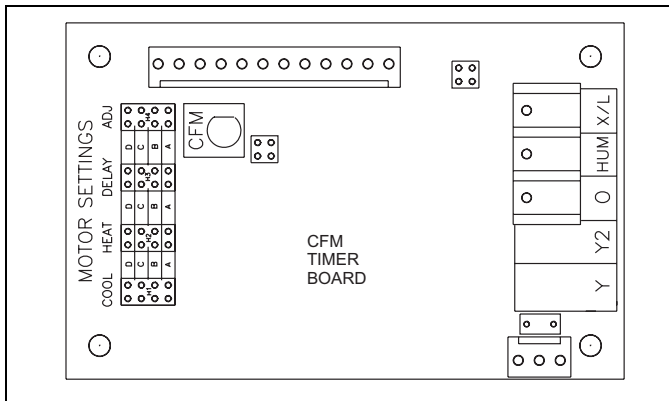

FIGURE 7: CFM / Timer Board

HEAT Taps Selection on the CFM / Timer Board

Pin Position A: will provide the highest CFM.

Pin Position B and C: are the medium and medium low CFM settings.

Pin Position D: will provide the lowest CFM.

Refer to Table 16 in the installation manual for the proper "HEAT" Taps Selection for the model furnace you are installing.

NOTE: When changing jumper positions, make sure that the jumper is pushed all the way on the pins. If the jumper is not making good contact or is left off completely, the blower will operate as if the jumper were in the "A" position.

NOTE: Power to the blower must be removed for at least 4 seconds after a heat or cool tap selection change, in order for the motor to recognize an adjustment. The fixed blower on delay and adjustable blower-off delay will function as described in the "OPERATION AND MAINTENANCE" Section in the Users Information Manual.

Heating Indoor Fan Off Delay

Changing the blower delay jumper on the Furnace Control Board can change the indoor fan "OFF" time delay. Refer to Figure 8 for the jumper settings to obtain the desired fan OFF delay. The blower off delay must be long enough to adequately cool the furnace, but not so long that cold air is blown into the living space.

The blower on delay is fixed at 30 seconds and cannot be adjusted.

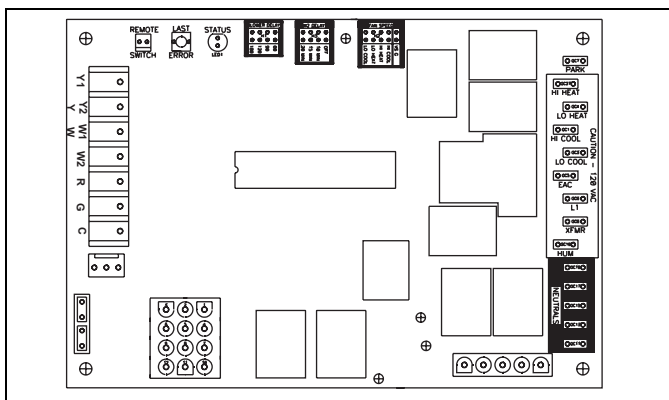

FIGURE 8: Furnace Control Board

Continuous Blower:

The blower will run continuously whenever the wall thermostat fan switch is in the "ON" position. The furnace blower will run at the speed selected on the "FAN SPEED" jumpers on the main control board (HI COOL, LO COOL, HI HEAT or LO HEAT). When the jumper is in the "VS G" position, the blower will run at 50% of the high cool speed.

COOLING AIRFLOW

CFM Board - Delay Tap Selection

The set of jumper pins on the CFM board labeled "DELAY" are used to set the delay profiles for the furnace. These can be chosen so as to maximize the comfort and sound levels for various regions of the country.

Tap A is the default profile. It provides a 15-second ramp-up from zero airflow to full capacity and a 15-second ramp-down from full capacity back to zero airflow. Whenever there is a change in airflow mode, such as from low heat to high heat, the motor will take 15 seconds to ramp from one speed to the other.

Tap B is the humid profile. This profile is best-suited for installations where the humidity is frequently very high during cooling season, such as in the southern part of the country. On a call for cooling, the blower will ramp up to 50% of full capacity and will stay there for two minutes, then will ramp up to 82% of full capacity and will stay there for five minutes, and then will ramp up to full capacity, where it will stay until the wall thermostat is satisfied. In every case, it will take the motor 15 seconds to ramp from one speed to the other.

Tap C is the dry profile. This profile is best suited to parts of the country where excessive humidity is not generally a problem, where the summer months are usually dry. On a call for cooling the motor will ramp up to full capacity and will stay there until the thermostat is satisfied. At the end of the cooling cycle, the blower will ramp down to 50% of full capacity where it will stay for 60 seconds. Then it will ramp down to zero. Any ramp up to a higher speed will take 30 seconds and any ramp down to a lower speed (or off) will take 60 seconds.

Tap D is the normal profile, best suited for most of the country, where neither excessive humidity nor extremely dry conditions are the norm. On a call for cooling, the motor will ramp up to 63% of full capacity and will stay there for 90 seconds, then will ramp up to full capacity. At the end of the cooling cycle, the motor will ramp down to 63% of full capacity and will stay there for 30 seconds, then will ramp down to zero. In every case, it will take the motor 15 seconds to ramp from one speed to another.

Hot Surface Ignition System

WARNING

HOT SURFACE IGNITION SYSTEM

Do not attempt to light this furnace by hand (with a match or any other means). There may be a potential shock hazard from the components of the hot surface ignition system. The furnace can only be lit automatically by its hot surface ignition system.

TROUBLESHOOTING

The following visual checks should be made before troubleshooting:

1. Check to see that the power to the furnace and the ignition control module is ON.
2. The manual shut-off valves in the gas line to the furnace must be open.
3. Make sure all wiring connections are secure.
4. Review the sequence of operation. Start the system by setting the thermostat above the room temperature. Observe the system's response. Then use the troubleshooting section in this manual to check the system's operation.

FURNACE DIAGNOSTICS

The furnace has built-in, self-diagnostic capability. If a system problem occurs, a blinking LED shows a fault code. The LED can flash red, green or amber to indicate various conditions. It is located behind a clear view port in the blower compartment door. The control continuously monitors its own operation and the operation of the system. If a failure occurs, the LED will indicate the failure code. If the failure is internal to the control, the light will stay on continuously. In this case, the entire control should be replaced, as the control is not field repairable. Flash sequence codes 1 through 11 are as follows: LED will turn "on" for 1/4 second and "off" for 1/4 second. This pattern will be repeated the number of times equal to the code. For example, six "on" flashes equals a number 6 fault code. All flash code sequences are broken by a 2 second "off" period.

STEADY OFF No power to board. Check the 24 vac control circuit fuse on the board or the circuit breakers on the 115 vac power to the furnace.

SLOW GREEN FLASH: Normal operation.

SLOW AMBER FLASH: Normal first stage operation with call for heat.

AMBER PULSE Normal second stage operation with call for heat.

3 FLASHES AMBER Indicates a second stage call for heat (Voltage present on the W2 terminal) with no single stage call for heat (No voltage present on the W1 terminal). This condition may be caused by a faulty thermostat or faulty thermostat wiring.

4 FLASHES AMBER This condition indicates a call for cooling (Voltage Present on the "Y" terminal) with no call for indoor fan operation (No voltage on the "G" terminal). This condition may be caused by a faulty thermostat or faulty thermostat wiring.

RAPID RED FLASH: Twinning error, incorrect 24V phasing. Check twinning wiring.

1 RED FLASH: This indicates that flame was sensed when there was not a call for heat. With this fault code the control will turn on both the inducer motor and supply air blower. A gas valve that leaks through or is slow closing would typically cause this fault.

2 RED FLASHES: This indicates that the normally open 1st stage pressure switch contacts are stuck in the closed position. The control confirms these contacts are open at the beginning of each heat cycle. This would indicate a faulty 1st stage pressure switch or mis-wiring.

3 RED FLASHES: This indicates the normally open 1st stage pressure switch contact did not close after the inducer was energized. This could be caused by a number of problems: faulty inducer, blocked vent pipe, broken pressure switch hose or faulty 1st stage pressure switch.

3 DOUBLE RED FLASHES: This indicates the normally open 2nd stage pressure switch contact did not close after the inducer was energized. This could be caused by a number of problems: faulty inducer, blocked vent pipe, broken pressure switch hose or faulty 2nd stage pressure switch.

4 RED FLASHES: This indicates that a primary or auxiliary limit switch has opened its normally closed contacts 5 consecutive times during a call for heat. With this fault code the control will operate the supply air blower and inducer. This condition may be caused by: dirty filter, improperly sized duct system, incorrect blower speed setting, incorrect firing rate or faulty blower motor.

5 RED FLASHES: This fault is indicated if the normally closed contacts in the rollout switch open. The rollout control is manually reset. If it has opened, check for proper combustion air, proper inducer operation, and primary heat exchanger failure or burner problem. Be sure to reset the switch and cycle power (24 VAC) to the control after correcting the failure condition.

6 RED FLASHES: This indicates that after the unit was operating, the pressure switch opened 4 times during the call for heat. If the main blower is in a "Delay on" mode it will complete it, and any subsequent delay off period. The furnace will lock out for one hour and then restart.

7 RED FLASHES: This fault code indicates that the flame could not be established. This no-light condition occurred 3 times (2 retries) during

the call for heat before locking out. Low gas pressure, faulty gas valve, dirty or faulty flame sensor, faulty hot surface ignitor or burner problem may cause this. The furnace will lock out for one hour and then restart.

8 RED FLASHES: This fault is indicated if the flame is lost 5 times (4 recycles) during the heating cycle. This could be caused by low gas pressure, dirty or faulty flame sensor or faulty gas valve. The furnace will lock out for one hour and then restart.

9 RED FLASHES: Indicates reversed line voltage polarity or faulty wiring. Both heating and cooling operations will be affected. Check polarity at furnace and branch. Check furnace grounding including the transformer ground and L1 and neutral connections.

10 RED FLASHES: Gas flow with no call for 1st stage heat. Check 1st stage gas valve and gas valve wiring.

10 DOUBLE RED FLASHES: 2nd stage gas valve failure. Check 2nd stage gas valve and gas valve wiring.

11 RED FLASHES: This indicates that a primary or auxiliary limit switch has opened its normally closed contacts and has remained open for more than five minutes. This condition is usually caused by a failed blower motor or blower wheel. Cycle power (24 VAC) to the control to reset the hard lockout condition after correcting the failure condition.

STEADY ON RED: Control failure. Replace control board. 60-MINUTE AUTOMATIC RESET FROM LOCKOUT: This control includes a "watchdog" type circuit that will reset from a lockout condition after 60 minutes. Operational faults 6,7,8 will be reset. This provides protection to an unoccupied structure if a temporary condition exists causing a furnace malfunction. An example would be a low incoming gas supply pressure preventing unit operation. When the gas pressure is restored, at some point the "watchdog" would restart the unit and provide heat for the house.

NOTE: If a flame is detected the control flashes the LED for 1/8 of a second and then enters a flame stabilization period.

DIAGNOSTIC FAULT CODE STORAGE AND RETRIEVAL

The control in this furnace is equipped with memory that will store up to five error codes to allow a service technician to diagnose problems more easily. This memory will be retained even in power to the furnace is lost. **Only a qualified service technician should use this feature.**

The control stores up to five separate error codes. If more than five error codes have occurred since the last reset, only the five most recent will be retained. The furnace control board has a button, labeled "**LAST ERROR**" that is used to retrieve error codes. This function will only work if there are no active thermostat signals. So any call for heating, cooling or continuous fan must be terminated before attempting to retrieve error codes.

To retrieve the error codes, push the **LAST ERROR** button. The **LED** on the control will then flash the error codes that are in memory, starting with the most recent. There will be a two-second pause between each flash code. After the error codes have all been displayed, the **LED** will resume the normal slow green flash after a five second pause. To repeat the series of error codes, push the button again.

If there are no error codes in memory, the **LED** will flash two green flashes. To clear the memory, push the **LAST ERROR** button and hold it for more than five seconds. The **LED** will flash three green flashes when the memory has been cleared, then will resume the normal slow green flash after a five-second pause.

WARNING

Never bypass pressure switch to allow furnace operation. To do so will allow furnace to operate under potentially hazardous conditions.

Do not try to repair controls. Replace defective controls with UPG Source 1 Parts.

Never adjust pressure switch to allow furnace operation.

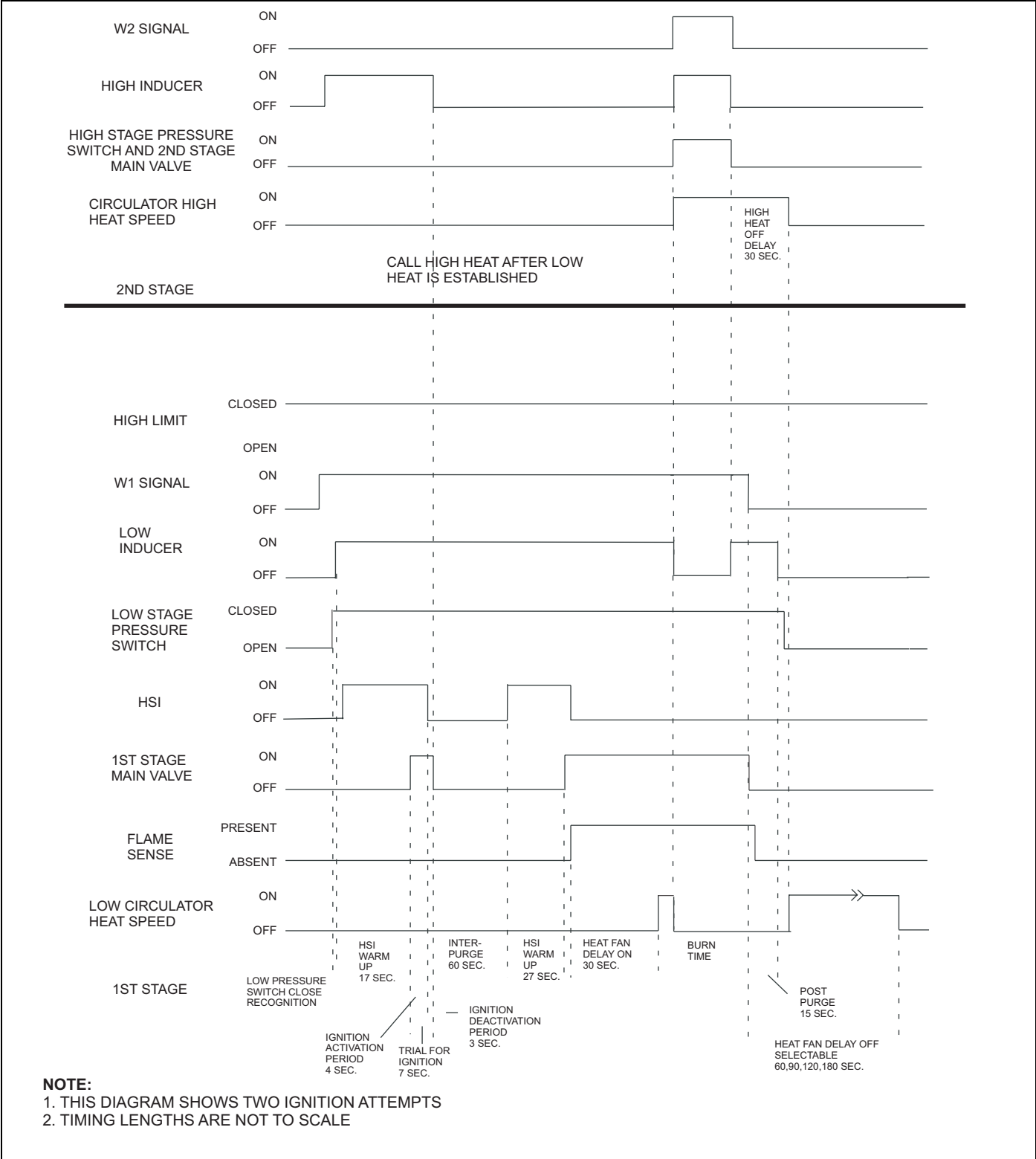
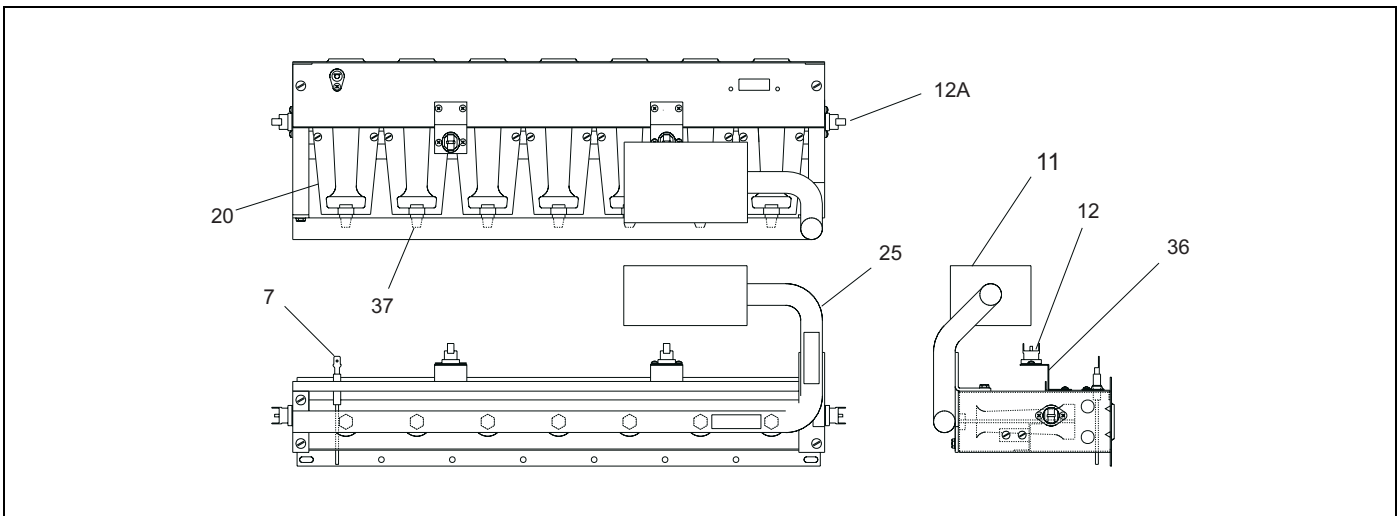
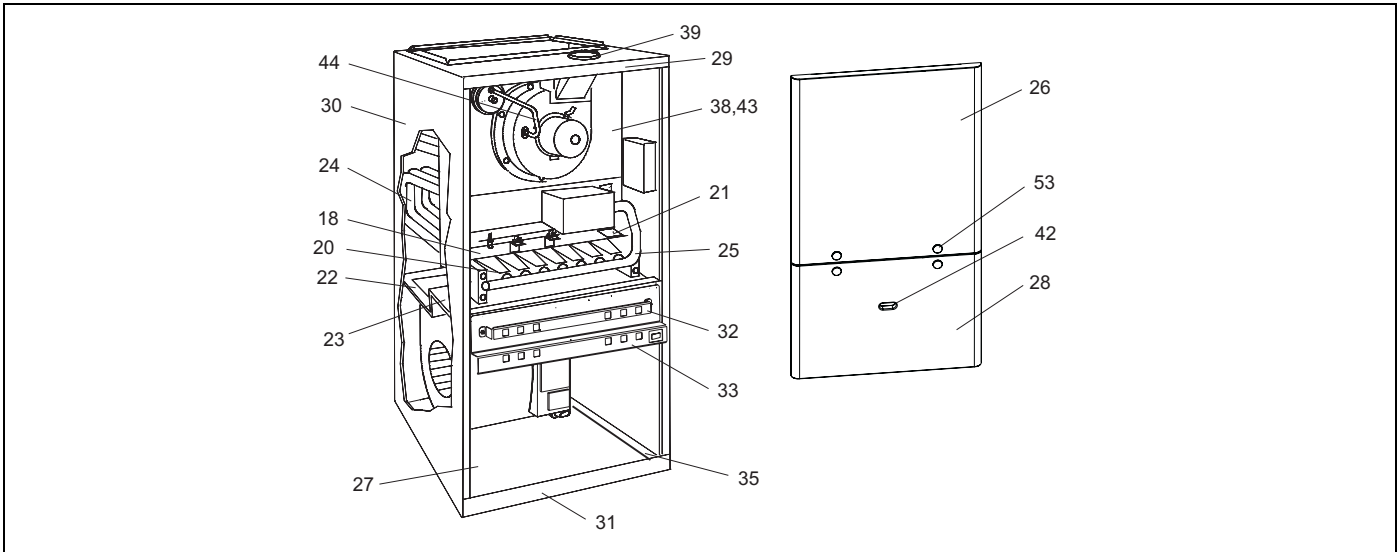
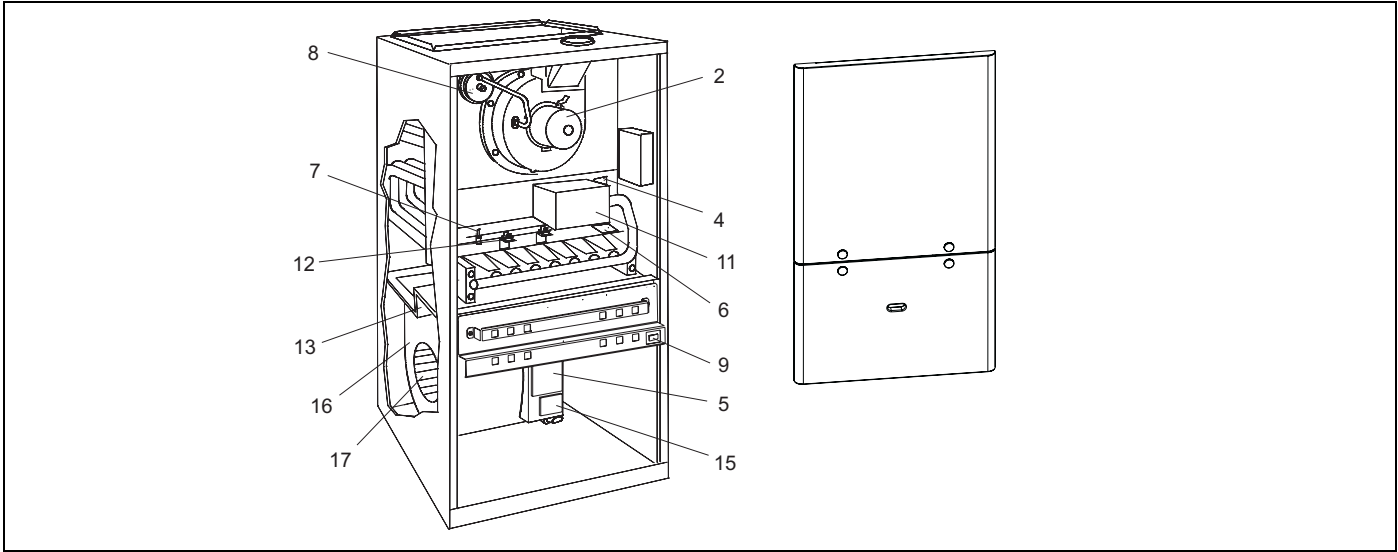

FIGURE 9: Furnace Control Event Schedule

SECTION III: REPLACEMENT PARTS LIST



ITEM	DESCRIPTION
MOTOR	
1*	MOTOR, DIRECT DRIVE BLOWER
2	MOTOR, VENTOR ASS'Y.
ELECTRICAL	
3	
4	CONTROL, HIGH LIMIT
5	CONTROL, FURNACE [FC]
6	IGNITER
7	SENSOR, FLAME
8	SWITCH, AIR PRESSURE [1LP]
9	SWITCH, DOOR [SW]
10	TRANSFORMER
11	VALVE, GAS
12	SWITCH, FLAME ROLL-OUT [ROS 3]
12A	CONTROL, Flame Roll Out (2ea.) [ROS1,2]
13	CONTROL, AUX. LIMIT (2 ea.) [LS2,LS3]
14*	FUSE (ARO 3)
15	CFM SELECTION BOARD
AIR MOVING	
16	HOUSING, BLOWER
17	WHEEL, BLOWER
FABRICATED PARTS	
18	PANEL, AIR SHIELD
19*	BAFFLE, FLUE
20	BURNER, MAIN GAS
21	BRACKET, IGNITOR
22	DECK, BLOWER (Rear)
23	DECK, FRONT
24	HEAT EXCHANGER ASS'Y
25	MANIFOLD, GAS
26	PANEL, UPPER ACCESS (Burner)
27	PAN, BASE

ITEM	DESCRIPTION
28	PANEL, BLOWER ACCESS
29	PANEL, TOP
30	WRAPPER, CABINET
31	CHANNEL, TOE PLATE
32	BRACKET, TOP DOOR
33	BRACKET, BOTTOM DOOR
34*	RACK, FILTER
35	FRAME, SIDE BASE (2 Req'd)
36	BRACKET, ROLL-OUT SWITCH
37	ORIFICE, BURNER (Natural #45)
38	PLATE, RESTRICTOR
39	COLLAR, FLUE
40*	LO-NOX SCREEN (LOW NOX ONLY)
MISCELLANEOUS	
41*	FILTER (.75 x 16 x 25)
42	SIGHT GLASS, OVAL
43	GASKET, RESTRICTOR PLATE
44	TUBING, SILICONE
45	
46*	DIAGRAM, WIRING
47*	HARNESS, MAIN WIRING
48*	ISOLATOR, TUBE (3 Req'd.)
49*	ISOLATOR, WASHER (3 Req'd.)
50*	ISOLATOR, SLEEVE (3 Req'd.)
51*	MOUNT, MOTOR
52*	GROMMET, 1/2" DIA.
53	KNOB, DOOR
54	RETAINER, DOOR KNOB
55	NUT, SELF THREADING
56*	RETAINER, SQUARE
57*	HARNESS, MOTOR WIRING (16 Pin)
58*	HARNESS, JUMPER

NOTE: *Not Shown

New replacement parts shown in **bold** face type at the first printing of parts list dated 11/02.

Major components and suggested stocking items are shown with shaded item number.



FIELD INSTALLED ACCESSORIES - NON-ELECTRICAL

FIELD INSTALLED ACCESSORIES - NON-ELECTRICAL		
MODEL NO.	DESCRIPTION	USED WITH
1NP0480	PROPANE (LP) CONVERSION KIT	ALL MODELS
1SR0302	EXTERNAL SIDE FILTER RACK (6-PACK)	ALL MODELS
1BR0314	EXTERNAL BOTTOM RETURN FILTER RACK WITH HIGH VELOCITY FILTER	ALL 14-1/2" ("A") UNITS
1BR0317		ALL 17-1/2" ("B") UNITS
1BR0321		ALL 21" ("C") UNITS
1PS0313	HIGH ALTITUDE PRESSURE SWITCH KIT (DOES NOT INCLUDE ORIFICES)	FOR APPLICATION INFORMATION SEE FORM 650.78-N1.1V
1PS0314		

REPLACEMENT PART CONTACT INFORMATION

This is a generic parts list. To request a complete parts list, refer to the contact information below:

- Visit our website at www.source1parts.com for the following information:
 1. Search for a part or browse the catalog.
 2. Find a dealer or distributor.
 3. Customer Service contact information.
 - a. Click on the "Brand Links" button
 - b. Click on the "Customer Service" button
- You can contact us by mail. Just send a written request to:

**York International
Consumer Relations
5005 York Drive
Norman, OK 73069**

NOTES

Limited Warranty

UPG warrants this product to be free from defects in factory workmanship and material under normal use and service and will, at its option, repair or replace any parts that prove to have such defects according to the terms outlined on this warranty. This warranty covers only the equipment described by the Product Model Number and Serial Number listed on the Warranty Registration Card.

UPG warrants the primary heat exchangers in the product to be free from defects in factory workmanship and material under normal use and service and will at its option, repair or furnish a replacement heat exchanger, either new or reconditioned, that meets the intended fit, use and function of the original heat exchanger for any heat exchanger furnished by UPG which proves to have such defects within the duration of warranty coverage. Alternatively, UPG may, at its option, extend a replacement allowance to be applied toward the purchase of a new furnace or packaged unit marketed by UPG. The exact amount of the allowance will be determined at the discretion of UPG, based upon current market conditions, but in no case shall this allowance exceed thirty (30) percent of the original consumer purchase price of the furnace, excluding such items as ductwork, wiring, piping and installation costs. UPG shall have no responsibility hereunder for installation, shipping, handling or other charges except as specifically provided herein.

For your benefit and protection, return the Warranty Registration Card to UPG promptly after installation. This will initiate the warranty period and allow us to contact you, should it become necessary. In the absence of a recorded Warranty Registration Card, the warranty period will begin upon product shipment from UPG.

This warranty extends only to the original consumer purchaser and is non-transferable. For this warranty to apply, the product must be installed according to UPG recommendations and specifications, and in accordance with all local, state, and national codes; and the product must not be removed from its place of original installation. The warranty period for repair or replacement parts provided hereunder shall not extend beyond the warranty period stated on the reverse side of this warranty.

FURNACE TYPE		HEAT EXCHANGER			PARTS
		Residential Applications		Non-Residential Applications	
		Original Owner	Subsequent Owner		
80%	PV8V / FC8V / FL8V / LC8V / LL8V	20	N/A	10	5

UPG strongly recommends regular periodic preventative maintenance on this equipment. The person most familiar with the equipment in your HVAC system is a UPG dealer. The UPG dealer can ensure your maintenance program meets the conditions of the "UPG Warranty", maximize the efficiency of the equipment, and service your unit within the mandated guidelines with regard to unlawful discharge of refrigerants into the atmosphere.

This warranty applies only to products installed in the United States and Canada.

EXCLUSIONS

This warranty does not cover any:

- Shipping, labor, or material charges.
- Damages resulting from transportation, installation, or servicing.
- Damages resulting from accident, abuse, fire, flood, alteration, or acts of God (tampering, altering, defacing or removing the product serial number will serve to void this warranty).
- Damages resulting from use of the product in a corrosive atmosphere.
- Damages resulting from inadequacy or interruption of electrical service or fuel supply, improper voltage conditions, blown fuses, or other like damages.
- Cleaning or replacement of filters.
- Damages resulting from failure to properly and regularly clean air and/or water side of condenser and evaporator.
- Damages resulting from: (I) freezing of condenser water or condensate; (II) inadequate or interrupted water supply; (III) use of corrosive water; (IV) fouling or restriction of the water circuit by foreign material or like causes.
- Damages resulting from operation with inadequate supply of air or water.
- Damages resulting from use of components or accessories not approved by UPG (vent dampers, etc.).
- Increase in fuel or electric cost.

THIS WARRANTY IS IN LIEU OF ALL OTHER WARRANTIES, EXPRESSED OR IMPLIED, INCLUDING THE IMPLIED WARRANTIES OF MERCHANTABILITY AND FITNESS FOR A PARTICULAR PURPOSE.

SOME STATES DO NOT ALLOW THE DISCLAIMER OF IMPLIED WARRANTY, SO THAT THE ABOVE DISCLAIMER MAY NOT APPLY TO YOU.

SOME STATES ALLOW ONLY A PARTIAL LIMITATION ON IMPLIED WARRANTIES TO LIMIT THE DURATION OF IMPLIED WARRANTIES TO THE DURATION OF THE EXPRESS WARRANTY. IN SUCH STATES, THE DURATION OF IMPLIED WARRANTIES IS HEREBY EXPRESSLY LIMITED TO THE DURATION OF THE EXPRESS WARRANTY ON THE FACE HEREOF.

IN NO EVENT, WHETHER AS A RESULT OF BREACH OF WARRANTY OR CONTRACT, TORT (INCLUDING NEGLIGENCE) STRICT LIABILITY OR OTHERWISE, SHALL UPG BE LIABLE FOR SPECIAL, INCIDENTAL, OR CONSEQUENTIAL DAMAGES, INCLUDING BUT NOT LIMITED TO LOSS OF USE OF THE EQUIPMENT OR ASSOCIATED EQUIPMENT, LOST REVENUES OR PROFITS, COST OF SUBSTITUTE EQUIPMENT OR COST OF FUEL OR ELECTRICITY. THE ABOVE LIMITATIONS SHALL INURE TO THE BENEFIT OF UPG'S SUPPLIERS AND SUBCONTRACTORS. THE ABOVE LIMITATION ON CONSEQUENTIAL DAMAGES SHALL NOT APPLY TO INJURIES TO PERSONS IN THE CASE OF CONSUMER GOODS.

SOME STATES DO NOT ALLOW THE EXCLUSION OR LIMITATION OF LIABILITY FOR CONSEQUENTIAL OR INCIDENTAL DAMAGES, OR FOR STRICT LIABILITY IN TORT, SO THAT THE ABOVE EXCLUSIONS AND LIMITATIONS MAY NOT APPLY TO YOU.

UPG DOES NOT ASSUME, OR AUTHORIZE ANY OTHER PERSON TO ASSUME FOR UPG, ANY OTHER LIABILITY FOR THE SALE OF THIS PRODUCT.

THIS WARRANTY GIVES YOU SPECIFIC LEGAL RIGHTS. YOU MAY ALSO HAVE OTHER RIGHTS WHICH VARY FROM STATE TO STATE.

For Owner's Information:

PRODUCT MODEL NO. _____ INSTALLATION DATE _____
 UNIT SERIAL NO. _____ INSTALLING DEALER _____